

INSTALLATION AND MAINTENANCE MANUAL

PRESSURE TRANSMITTER

Type ST18



Servicing Department
e-mail servicing@conflow.it
www.conflow.it

Index

1. IMPORTANT INFORMATION	2
2. SAFETY INSTRUCTIONS	2
3. INTENDED USE	3
4. ELECTRICAL CONNECTIONS	3
5. INSTALLATION	3
6. RECALIBRATION AND MAINTENANCE	4
7. DISPOSAL AND DEMOLITION	4

1. Important information

Please read carefully this information before installation and use of the instrument. Keep it in a safe and accessible place for every user.

The instrument safety level depends on the right choose and installation of the instrument model and on the respect of the maintenance procedures established by the producer.

Technicians in charge of the instrument selection, installation and maintenance should be able to understand if the instrument conditions of use could affect its right functioning and lead to any premature damage or breaking.

It is essential that these procedures included in the plants regulations should be carried out by qualified staff . An improper use could be dangerous for the instrument itself and cause breakings and damages to the staff and to the plant.

CE	In accordance with directive	Standards of reference: EN 61326
	EMC 2004/108/CE – PED 2014/68/UE	IEC 60770 – IEC 61298-2

2. Safety Instructions



- The manufacturer disclaims all responsibility in case of damages caused by the improper use of the product and by the non-respect of the instructions reported in this manual.
- Follow carefully the specific safety rules in case of measuring oxygen pressure, acetylene, inflammable or toxic gas or liquids.
- Disconnect the instruments only after depressurization of the system.
- The process fluids residuals in the disassembled instruments could affect people, the environment and the system. It is highly recommended to take proper precautions.



- Before installation be sure that the right instrument has been selected following the working conditions and in particular the range, the working temperature and the compatibility between the material used and the process fluid.
- This manual does not concern the instruments conforming to standard 94/9/CE (ATEX).
- The product warranty is no longer valid in case of non-authorized modifications and of wrong use of the product.
- The user is totally responsible for the instrument installation and maintenance.
- Handle and carefully stock the instrument used for toxic or inflammable liquids measurement

3. Intended use

The pressure transmitter turns the input pressure into an output electrical signal. The electrical signal changes in proportion to the input pressure level.

4. Electrical connections

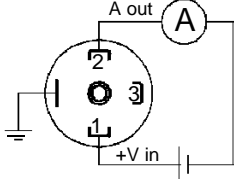
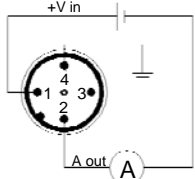
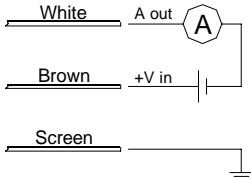
		EN 175301-803 Form A	M12x1	Wire Output
		EN 175301-803 Form C		
Output signal:	4...20 mA			
N° of wires:	2			
Charge (Ohm):	$R_L - (V_{in}-10)/0,02$			
Input +Vin:	10...30			

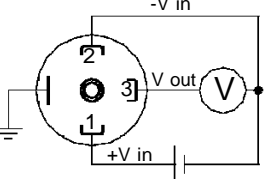
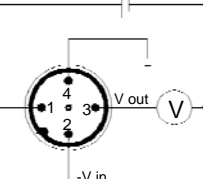
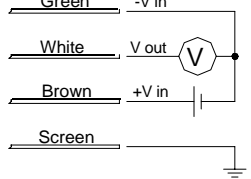
			EN 175301-803 Form A	M12x1	Wire Output
			EN 175301-803 Form C		
Output signal:	0...5 Vdc	0...10 Vdc			
N° of wires:	3	3			
Charge (Ohm):	min. 10Kohm	min. 10Kohm			
Input +Vin:	8...30	14...30			

The transmitter metal case should always be connected to ground through the process connection thread in order to protect it from disturbances due to electromagnetic fields or electrostatic charges. If it wouldn't be possible to do so connect the transmitter to ground through the connector and the cable screen.

5. Installation

Before installing electrical instrument safely and securely into a plant or a system the user should verify the instrument suitability to the plant characteristics and the correct installation. After installation the user should verify that the instrument is not exposed to any source of heat exceeding the established ambient limits.

Secure the instrument thread through a special key/wrench on the process connection hexagon without grasping the case by the hands.

Secure the instrument thread through a special key/wrench on the process connection hexagon (20...30Nm). The correct torque depends on the type of process connection and the type of seal used (form and material).

If the connection thread is conical the instrument is tightened through a simple screwing on the plug. In order to improve the thread tightness it is recommended to place a PTFE layer on the male thread.

If the instrument is equipped with a fluid diaphragm seal the connection should be clamped on the diaphragm otherwise the calibration could be compromised.

Instruments showing symbol.

Instruments with process connection DIN 11851 must be installed with special adapter SKS.

Instruments with process connection ISO 2853 (IDF/ISS) must be installed using gaskets with supporting ring according to the above mentioned standard.

Connector Assembling EN 175301-803 Form A

Disassemble the connector as in fig.1 and connect the cable as in fig.2.

Reassemble the connector and fix it on the transmitter.



Figure 1 – Exploded view of the connector

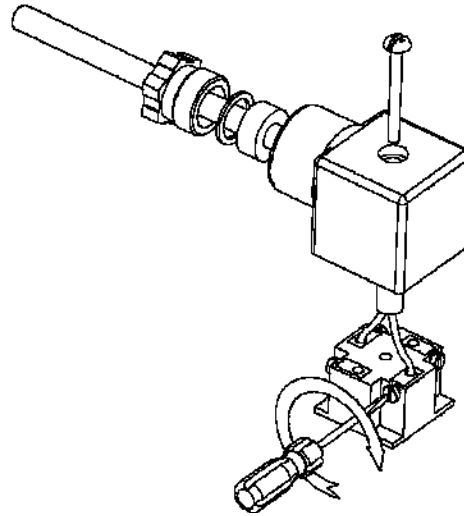

Figure 2 – Wires connections



The IP grade according to standard EN 60529-1:1992 is guaranteed only if the female connector equipped with a connection cable is mounted on the instrument and all the other components are assembled correctly

6. Recalibration and maintenance

In some models the zero and the full scale range can be adjusted as follows (see figure 3):

- Connector disassembling (see fig. 1)
- Zero adjustment (Z)
- Span adjustment(S)

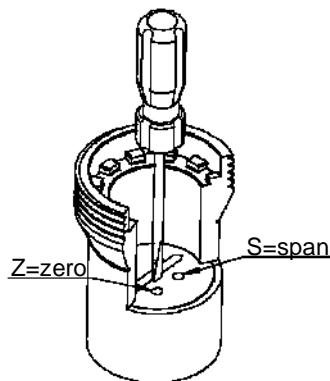

Figure 3 - Adjustment

7. Disposal and demolition

Dispose of instrument components and packaging materials in an environmentally compatible way and in accordance with the rules of the specific waste in the country of origin.