

ELECTRIC ACTUATORS TENSION OPENS and CLOSES



PSL/E

10 | 2012



TYPE PSL...

TYPE PSL-AMS...(Smart)

DESCRIPTION

The PSL valve actuators fulfil all requirements for control valve actuators with remarkable efficiency. They position precisely, are very robust, reliable with long life, even at high loads. The individual components are of high quality and correspond to the harmonized European standards for machines and electrical equipment. The basic adjustment of a PSL actuator on a valve is simple due to the central arrangement of the switching and sensors units, which are easily accessible. Optional accessories are quickly retrofittable due to the unique, perfected modular design.

The PS-AMS valve actuators are SMART type solution. The speed-controlled actuation is generated by a 24 VDC motor, which is controlled by the electronics via pulse width modulation.

SMART version permits parameterization by software and diagnostics function.

PSL NOMINAL SIZES :

- **PSL 201** 1 kN maximum
- **PSL 202** 2 kN maximum
- **PSL 204** 4,5 kN maximum
- **PSL 210** 10 kN maximum
- **PSL 214** 14 kN maximum
- **PSL 320** 20 kN maximum
- **PSL 325** 25 kN maximum

FINISHING :

- Gear case material epoxy coated
- Cover high quality UV resistant self-extinguishing polycarbonate
Yellow colour – other colour on request

CONFORMITY :

- 89/336/EEC
- 73/23/EEC

PSL TECHNICAL CHARACTERISTICS :

- Modulating Actuator : Class C EN 15714-2
- Enclosure : IP 65 EN 60529
- Supply V : 230 V AC 1~
: 115 V AC 1~
: 24 V AC 1~
: 400 V AC 3~
: 24 VDC
- Cable entries : n°2 PG13

OPTION on PSL series :

- Potentiometer or double potentiometer
- Positioner
- Position transmitter (feedback)
- Position switches
- Space heater
- Enclosure IP67 with metal cover
- Reversing starter contactor only on 400 V AC 3~

PSL-AMS NOMINAL SIZES :

- **PSL 202/AMS11** max 2,3 kN adjustable closing force
- **PSL 204/AMS11** max 4,5 kN adjustable closing force
- **PSL 210/AMS11/12** max 10 kN adjustable closing force
- **PSL 214/AMS12** max 14 kN adjustable closing force
- **PSL320/AMS13** max 20 kN adjustable closing force
- **PSL325/AMS13** max 25 kN adjustable closing force

CONFORMITY :

- 89/336/EEC
- 73/23/EEC

PSL-AMS TECHNICAL CHARACTERISTICS :

- Intelligent Modulating Act. : Class C EN 15714-2
- Positioner integrated
- Setpoint control
- Actual value feedback
- Automating commissioning
- Torque increase
- Internal fault monitoring
- Diagnostic function
- Communication interface

- Enclosure : IP 65 EN 60529
- Supply V : 230 V AC 1~
: 115 V AC 1~
: 24 V AC 1~
: 24 VDC

OPTION on PSL-AMS series :

- Position switches
- Binary inputs 230 VAC
- Fail Safe
- Fieldbus interface
- Local control
- Data cable
- IP67
- Heating resistor

Page 1 / 8

CONFLOW s.p.a.

FLOW CONTROL SOLUTIONS

COMPANY
WITH QUALITY SYSTEM
CERTIFIED BY DNV

ISO 9001

Factory & Sales Offices:

Via Lecco, 69/71
20864 AGRATE BRIANZA (MB)
ITALYTel. +39.(0)39/651.705 - 650.397
Fax. +39.(0)39/654.018www.conflow.it / sales@conflow.it

Performances

Type	PSL 201 – 1 kN				
Maximum stroke	50 mm				
Velocity	0,5 mm/s (50Hz) / 0,6 mm/s (60Hz)				0,45 mm/s
Power supply	230 VAC 1~	115 VAC 1~	24 VAC 1~	400 V 3~	24 VDC
Frequency (Hz)	50/60	50/60	50/60		-
Rated current(A)	0,03 / 0,03	0,06 / 0,06	0,26 / 0,28		1,0
Max power Consumption (VA)	25,5 / 25,9	25,5 / 25,9	25,5 / 25,9		41
Duty cycle IEC60034-1	S2 30 min / S4 80%-ED @ 25 °C				S2 30 min @ 25°C
Ambient temp. (°C)	-20 °C to + 80 °C (S2) / -20 °C to + 80 °C (S4)				Ditto
Motor Protection	Blockable				Multifuse

Type	PSL 201.1 – 1 kN				
Maximum stroke	50 mm				
Velocity	0,5 mm/s (50Hz) / 0,6 mm/s (60Hz)				0,45 mm/s
Power supply	230 VAC 1~	115 VAC 1~	24 VAC 1~	400 V 3~	24 VDC
Frequency (Hz)	Not Available	Not Available	Not Available	Not Available	-
Rated current(A)					1,0
Max power Consumption (VA)					41
Duty cycle IEC60034-1					S2 30 min @ 25°C
Ambient temp. (°C)	-20 °C to + 80 °C (S2) / -20 °C to + 80 °C (S4)				Ditto
Motor Protection	Blockable				Multifuse

Type	PSL 202 – 2 kN				
Maximum stroke	50 mm				
Velocity	0,25 mm/s (50Hz) / 0,3 mm/s (60Hz)				
Power supply	230 VAC 1~	115 VAC 1~	24 VAC 1~	400 V 3~	24 V DC
Frequency (Hz)	50/60	50/60	50/60	Not Available	-
Rated current(A)	0,08 / 0,09	0,15 / 0,18	0,75 / 0,87		-
Max power Consumption (VA)	37 / 40	37 / 40	37 / 40		0,3
Duty cycle IEC60034-1	S2 30 min / S4 80%-ED @ 25 °C				Ditto
Ambient temp. (°C)	-20 °C to + 80 °C (S2) / -20 °C to + 80 °C (S4)				Ditto
Motor Protection	Blockable				Multifuse

Type	PSL 202.1 – 2 kN				
Maximum stroke	50 mm				
Velocity	0,25 mm/s (50Hz) / 0,3 mm/s (60Hz)				
Power supply	230 VAC 1~	115 VAC 1~	24 VAC 1~	400 V 3~	24 V DC
Frequency (Hz)	50/60	50/60	50/60	Not Available	Not Available
Rated current(A)	0,04 / 0,05	0,08 / 0,09	0,38 / 0,43		
Max power Consumption (VA)	28,2 / 29,4	28,2 / 29,4	28,2 / 29,4		
Duty cycle IEC60034-1	S2 30 min / S4 80%-ED @ 25 °C				
Ambient temp. (°C)	-20 °C to + 80 °C (S2) / -20 °C to + 80 °C (S4)				
Motor Protection	Blockable				

Type	PSL 202.2 – 2 kN				
Maximum stroke	50 mm				
Velocity	0,25 mm/s (50Hz) / 0,3 mm/s (60Hz)				
Power supply	230 VAC 1~	115 VAC 1~	24 VAC 1~	400 V 3~	24 V DC
Frequency (Hz)	50/60	50/60	50/60	50/60	-
Rated current(A)	0,11 / 0,09	0,22 / 0,18	1,05 / 0,88	0,06 / 0,05	1,0
Max power Consumption (VA)	44 / 40	44 / 40	44 / 40	62 / 54	41
Duty cycle IEC60034-1	S2 30 min / S4 80%-ED @ 25 °C				
Ambient temp. (°C)	-20 °C to + 80 °C (S2) / -20 °C to + 80 °C (S4)				
Motor Protection	Thermo switch				Multifuse

Type	PSL 204 – 4,5 kN				
Maximum stroke	50 mm				
Velocity	0,5 mm/s (50Hz) / 0,6 mm/s (60Hz)				
Power supply	230 VAC 1~	115 VAC 1~	24 VAC 1~	400 V 3~	24 V DC
Frequency (Hz)	50/60	50/60	50/60	Not Available	Not Available
Rated current(A)	0,11 / 0,12	0,22 / 0,25	1,0 / 1,2		
Max power Consumption (VA)	44 / 47	44 / 47	44 / 47		
Duty cycle IEC60034-1	S2 30 min / S4 80%-ED @ 25 °C				
Ambient temp. (°C)	-20 °C to + 80 °C (S2) / -20 °C to + 60 °C (S4)				
Motor Protection	Thermo switch				

Performances

Type	PSL 204.1 – 4,5 kN					
Maximum stroke	50 mm					
Velocity	1,0 mm/s (50Hz) / 1,2 mm/s (60Hz)				1,0 mm/s	
Power supply	230 VAC 1~	115 VAC 1~	24 VAC 1~	400 V 3~	24 VDC	
Frequency (Hz)	50/60	50/60	50/60	Not Available	-	
Rated current(A)	0,23 / 0,21	0,46 / 0,42	0,26 / 0,28		1,0	
Max power Consumption (VA)	25,5 / 25,9	25,5 / 25,9	2,2 / 2,01		41	
Duty cycle IEC60034-1	S2 30 min / S4 50%-ED @ 25 °C				=	
Ambient temp. (°C)	-20 °C to + 80 °C (S2) / -20 °C to + 60 °C (S4)				Ditto	
Motor Protection	Thermo switch				Multifuse	

Type	PSL 204.2 – 4,5 kN				
Maximum stroke	50 mm				
Velocity	1,4 mm/s (50Hz) / 1,7 mm/s (60Hz)				0,45 mm/s
Power supply	230 VAC 1~	115 VAC 1~	24 VAC 1~	400 V 3~	24 VDC
Frequency (Hz)	50/60	50/60	50/60	50/60	Not Available
Rated current(A)	0,27 / 0,23	0,54 / 0,45	2,5 / 2,2	0,12 / 0,09	
Max power Consumption (VA)	81 / 72	81 / 72	81 / 72	102 / 85	
Duty cycle IEC60034-1	S2 30 min / S4 50%-ED @ 25 °C				
Ambient temp. (°C)	-20 °C to + 80 °C (S2) / -20 °C to + 60 °C (S4)				
Motor Protection	Thermo switch				

Type	PSL 210 – 10 kN					
Maximum stroke	50 mm					
Velocity	0,45 mm/s (50Hz) / 0,54 mm/s (60Hz)					
Power supply	230 VAC 1~	115 VAC 1~	24 VAC 1~	400 V 3~	24 V DC	
Frequency (Hz)	50/60	50/60	50/60	Not Available	-	
Rated current(A)	0,22 / 0,23	0,43 / 0,45	2 / 2.3		1	
Max power Consumption (VA)	51 / 53	51 / 53	51 / 53		41	
Duty cycle IEC60034-1	S2 30 min / S4 50%-ED @ 25 °C				Ditto	
Ambient temp. (°C)	-20 °C to + 80 °C (S2) / -20 °C to + 60 °C (S4)				-	
Motor Protection	Thermo switch				Multifuse	

Type	PSL 214 – 14 kN				
Maximum stroke	65 mm				
Velocity	0,45 mm/s (50Hz) / 0,54 mm/s (60Hz)				
Power supply	230 VAC 1~	115 VAC 1~	24 VAC 1~	400 V 3~	24 V DC
Frequency (Hz)	50/60	50/60	50/60	50/60	-
Rated current(A)	0,22 / 0,23	0,43 / 0,45	2 / 2.3	0,13	2,7
Max power Consumption (VA)	51 / 53	51 / 53	51 / 53	50	93
Duty cycle IEC60034-1	S2 30 min / S4 50%-ED @ 25 °C				
Ambient temp. (°C)	-20 °C to + 80 °C (S2) / -20 °C to + 60 °C (S4)				
Motor Protection	Thermo switch				Multifuse

Type	PSL 320 – 20 kN				
Maximum stroke	100 mm				
Velocity	1 mm/s (50Hz) / 1,2 mm/s (60Hz)				
Power supply	230 VAC 1~	115 VAC 1~	24 VAC 1~	400 V 3~	24 V DC
Frequency (Hz)	50/60	50/60	50/60	50/60	-
Rated current(A)	0,35 / 0,29	0,65 / 0,54	3,2 / 2,7	0,22 / 0,18	2,5
Max power Consumption (VA)	100 / 86	100 / 86	100 / 86	119 / 103	60
Duty cycle IEC60034-1	S2 30 min / S4 50%-ED @ 1200 c/h				
Ambient temp. (°C)	-20 °C to + 80 °C (S2) / -20 °C to + 60 °C (S4)				
Motor Protection	Thermo switch				Multifuse

Type	PSL 325 – 25 kN				
Maximum stroke	100 mm				
Velocity	1 mm/s (50Hz) / 1,2 mm/s (60Hz)				
Power supply	230 VAC 1~	115 VAC 1~	24 VAC 1~	400 V 3~	24 V DC
Frequency (Hz)	50/60	50/60	50/60	50/60	Not Available
Rated current(A)	0,35 / 0,29	0,65 / 0,54	3,2 / 2,7	0,22 / 0,18	
Max power Consumption (VA)	100 / 86	100 / 86	100 / 86	119 / 103	
Duty cycle IEC60034-1	S2 30 min / S4 50%-ED @ 1200 c/h				
Ambient temp. (°C)	-20 °C to + 80 °C (S2) / -20 °C to + 60 °C (S4)				
Motor Protection	Thermo switch				

Construction Materials

Item	Description	Material
1	Manual handwheel	Duroplastic
2	Cover	UV resistant, self extinguishing polycarbonate – yellow colour
3	Base case with internal gears	Alluminium die casting
4	Coupling	Polyamide
5	Coupling nut	Steel 16 MnCr S5
6	Pillars	Non corrosive steel 1.4104



Dimensions (mm) and weight (Kg)

Type PSL 201 – 201.1 / Type PSL 202 – 202.1 – 202.2 / Type PSL 204 – 204.1 – 204.2

Pillars version "A"

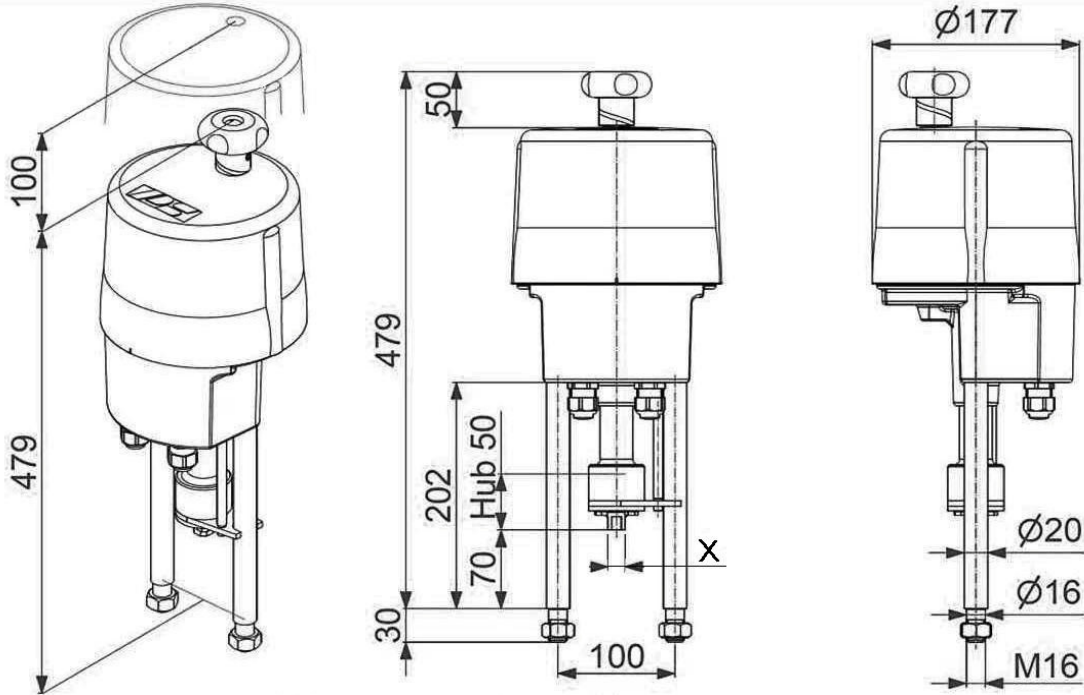

Connection Thread (female) X

M12	Standard
M8 – M10 – M14 – M16	Optional

Weight Kg.

PSL 201 – 201.1	PSL 202 – 202.1 – 202.2	PSL 204 – 204.1 – 204.2
4,3	4,5	5,5

Pillars version "B"

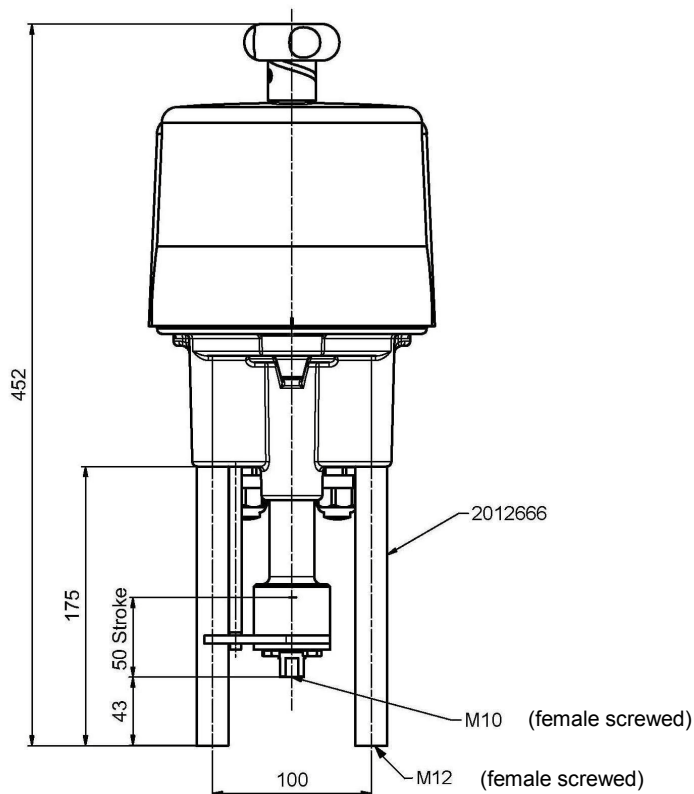

Type PSL 210

Pillars Version "A"

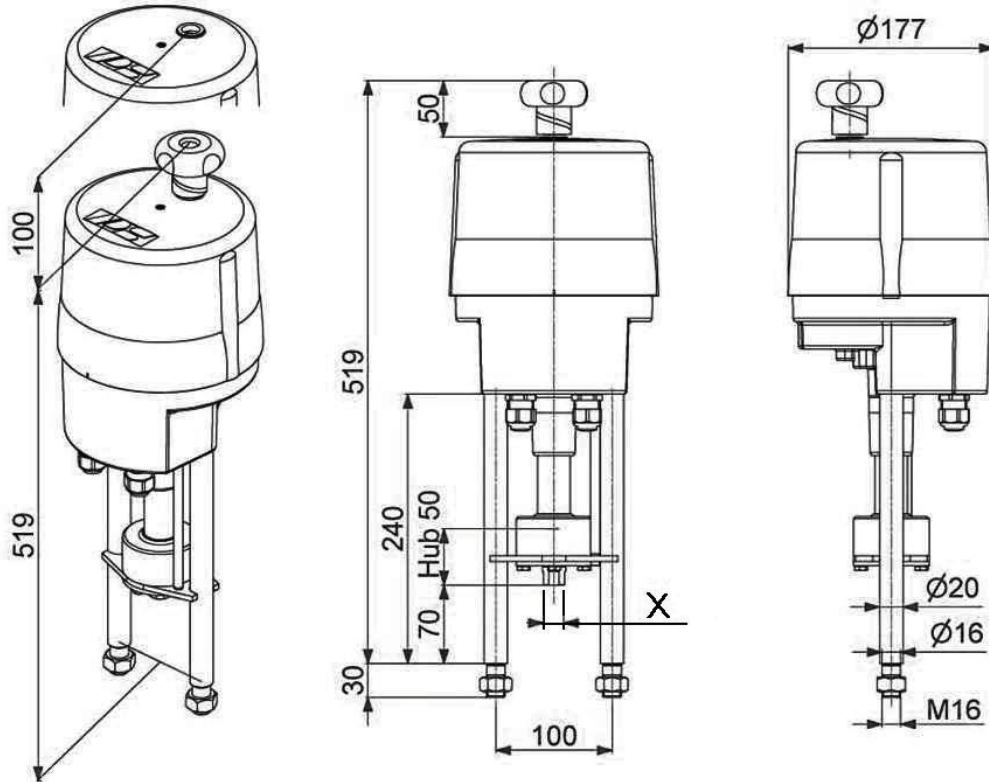

Weight 7,5 Kg

Connection Thread (female) X

M12
M8 – M10 – M14 – M16

Standard
Optional

Pillars version "B"

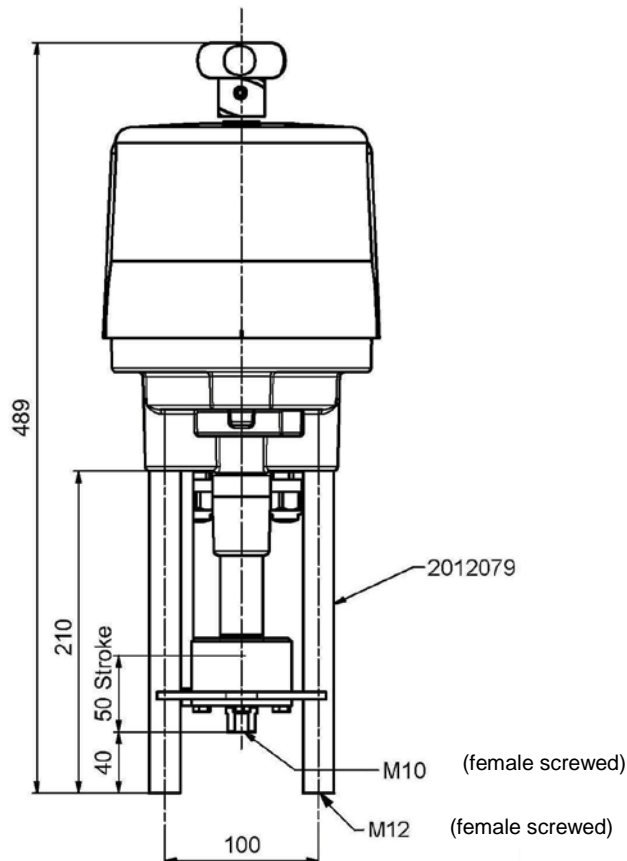

Type PSL 214

Version "A" pillars

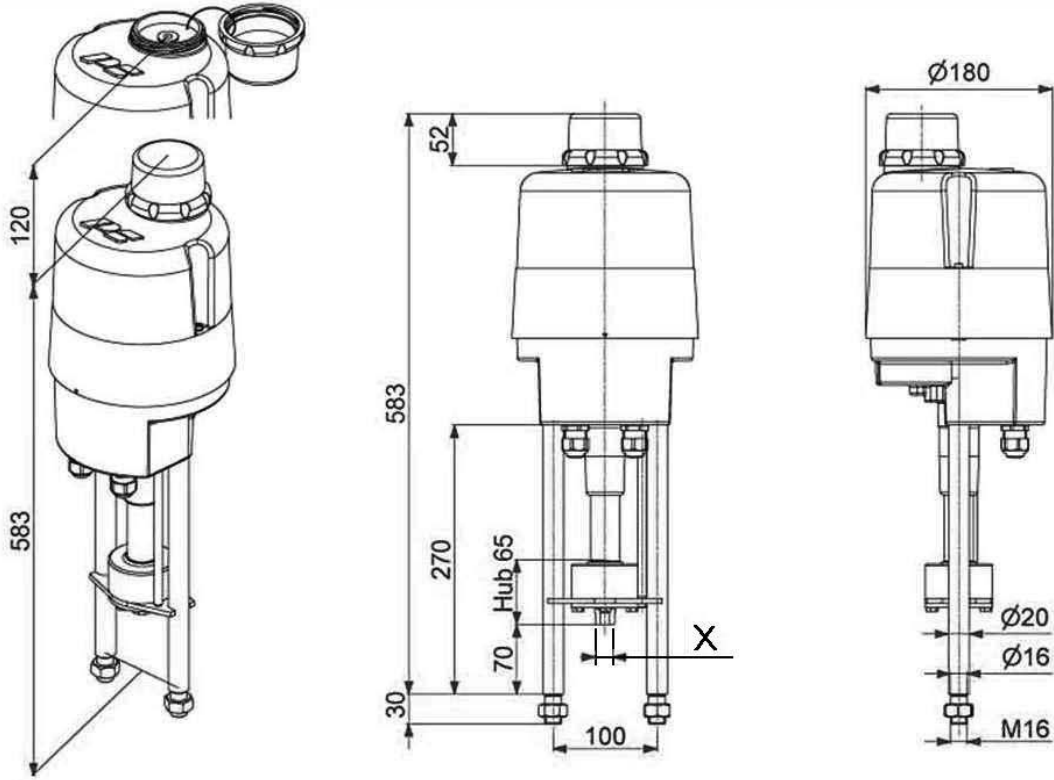

Weight 10 Kg

Connection Thread (female) X

M12	Standard
M8 – M10 – M14 – M16	Optional

Version "B" pillars

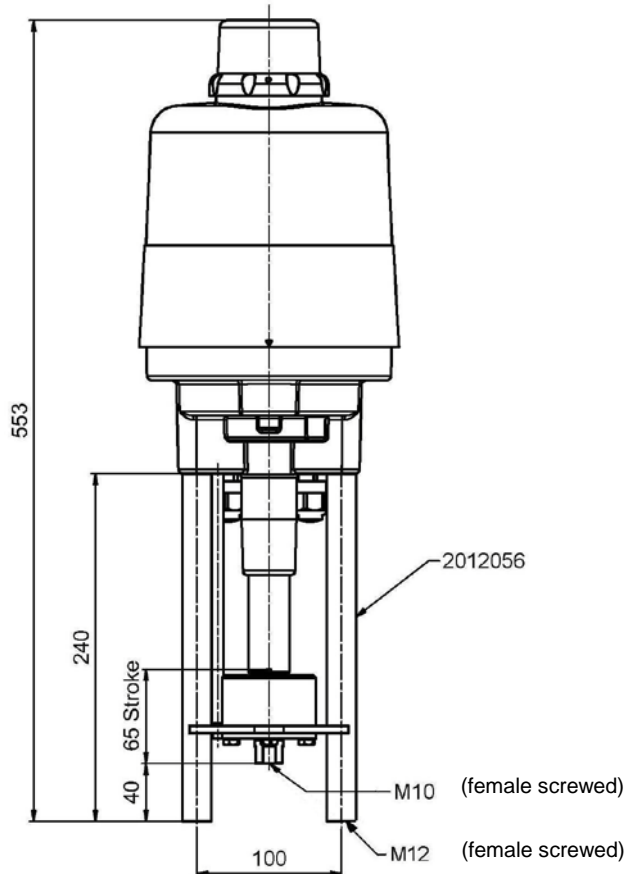

Dimensions (mm) and weight (Kg)

Type PSL 320 - 325

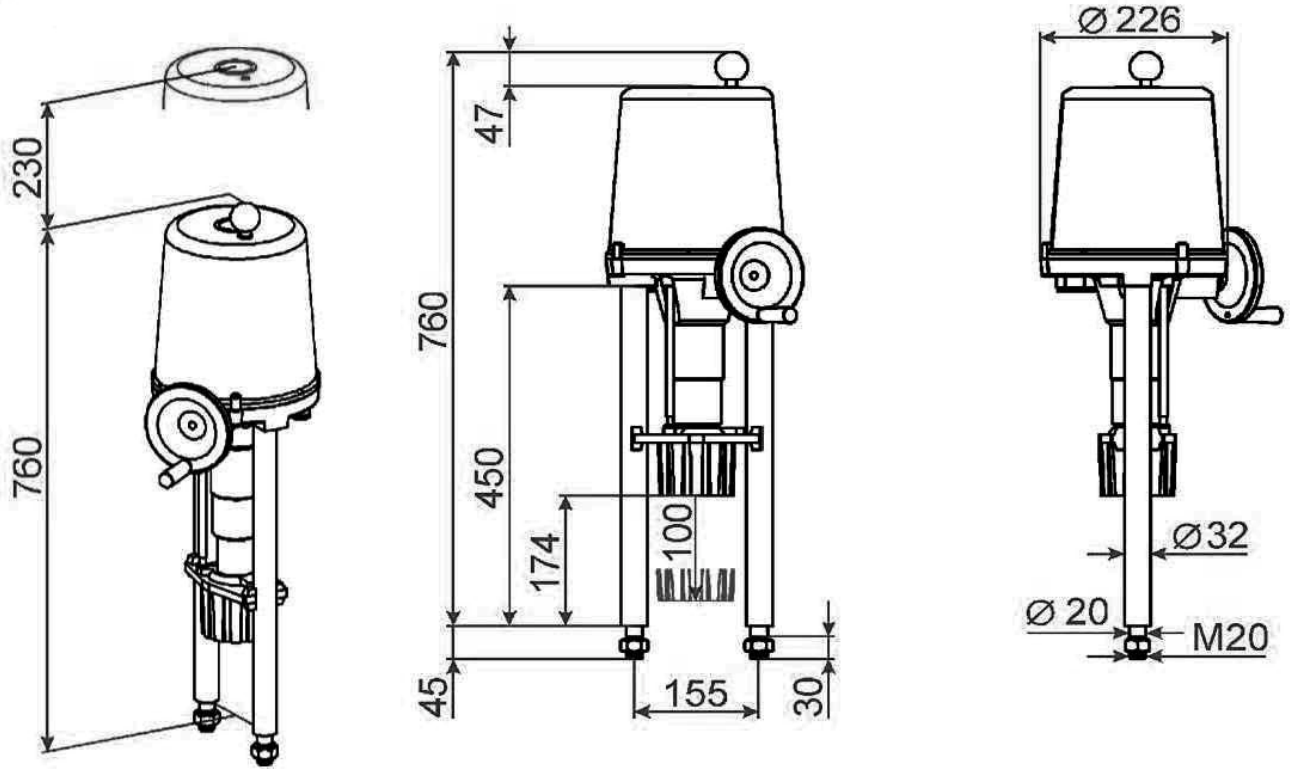

Weight 20 Kg

STANDARD COUPLING

Through Valve
Closing Direction : Retracting Valve Stem

3 - Way Valve

Through Valve
Closing Direction : Extracting Valve Stem

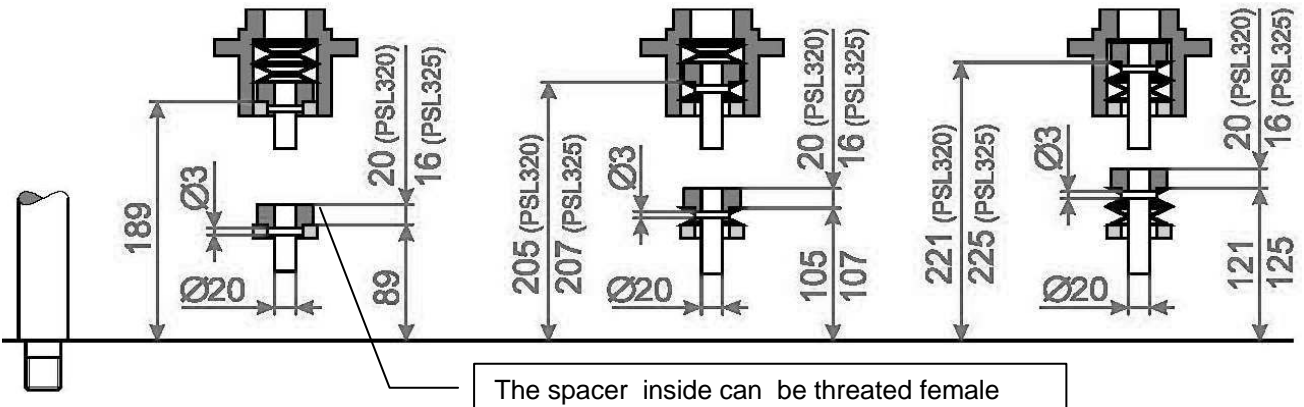

Specifications given are only indicative and not binding for the manufacturer who reserve the right to carry-out any modifications deemed necessary without prior notice. All data sheets by CONFLOW SpA, are available last update on our internet web site www.conflo.it.