

# Instruction and Operating Manual

## Valve Monitoring Controller LSB-7 Series

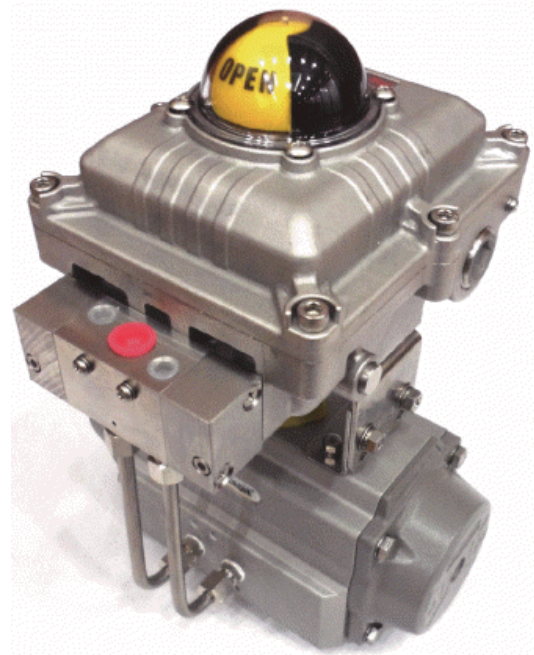

< LSB-7 >



< LSB-7S >

**Power-Genex Ltd.**



## Contents

1. Safety Instructions and Precautions	2
2. Overview of Structure	6
3. Specifications	7
4. Description on Nameplate	7
5. Part Numbering System (Order Code)	9
6. Specifications of Switches and Proximity Sensors	9
6.1. Mechanical Switches	
6.1.1. SPDT, SZM-V16-2FA-61 (made by STARION)	
6.1.2. DPDT, DZ-10G (made by OMRON)	
6.2. Proximity Sensors	
6.2.1. NJ2-V3-N (made by Pepperl & Fuchs)	10
6.2.2. NJ2-12GM-N (made by Pepperl & Fuchs)	
7. Specifications of Position Transmitter	10
8. Operating Principle of Solenoid Valve	11
8.1 Manual Button on Solenoid Valve	
9. Installation	12
10. Electrical Connections	13
11. Setting of Cams and Switches	16
12. Dimensions	17



## Safety Instructions 1

These safety instructions are intended to prevent hazardous situations and/or equipment damage. These instructions indicate the level of potential hazard with the labels of “**Caution**,” “**Warning**” or “**Danger**.” They are all important notes for safety and must be followed in addition to International Standards (IEC Note 1) and other safety regulations.

Note 1) IEC 60079-0: 2007, IEC 60079-1: 2007



### Caution

**Caution** indicates a hazard with a low level of risk which, if not avoided, could result in minor or moderate injury.



### Warning

**Warning** indicates a hazard with a medium level of risk which, if not avoided, could result in death or serious injury.



### Danger

**Danger** indicates a hazard with a high level of risk which, if not avoided, will result in death or serious injury.



## Warning

### 1. The compatibility of the product is the responsibility of the person who designs the equipment or decides its specifications.

Since the product specified here is used under various operating conditions, its compatibility with specific equipment must be decided by the person who designs the equipment or decides its specifications based on necessary analysis and test results. The expected performance and safety assurance of the equipment will be the responsibility of the person who has determined its compatibility with the product. This person should also continuously review all specifications of the product referring to its latest catalogue information, with a view to giving due consideration to any possibility of equipment failure when configuring the equipment.

### 2. Only personnel with appropriate training should operate machinery and equipment. The product specified here may become unsafe if handled incorrectly.

The assembly, operation and maintenance of machines or equipment including our products must be performed by an operator who is appropriately trained and experienced.

### 3. Do not service or attempt to remove product and machinery/equipment until safety is confirmed.

1. The inspection and maintenance of machinery/equipment should only be performed after measures to prevent falling or runaway of the driven objects have been confirmed.

2. When the product is to be removed, confirm that the safety measures as mentioned above are implemented and the power from any appropriate source is cut, and read and understand the specific product precautions of all relevant products carefully.

3. Before machinery/equipment is restarted, take measures to prevent unexpected operation and malfunction.

### 4. Contact POWER-GENEX beforehand and take special consideration of safety measures if the product is to be used in any of the following conditions.

1. Conditions and environments outside of the given specifications, or use outdoors or in a place exposed to direct sunlight.

2. Installation on equipment in conjunction with atomic energy, railways, air navigation, space, shipping, vehicles, military, medical treatment, combustion and recreation, or equipment in contact with food and beverages, emergency stop circuits, clutch and brake circuits in press applications, safety equipment or other applications unsuitable for the standard specifications described in the product catalogue.

3. An application which could have negative effects on people, property, or animals requiring special safety analysis.

4. Use in an interlock circuit, which requires the provision of double interlock for possible failure by using a mechanical protective function, and periodical checks to confirm proper operation.

### 5. Do not open when an explosive gas and dust atmosphere may be present

### 6. Do not touch the visual indicator in electrostatic hazardous areas.



## Safety Instructions 2



### Caution

**1. The product is provided for use in manufacturing industries.**

The product herein described is basically provided for peaceful use in manufacturing industries. If considering using the product in other industries consult POWER-GENEX beforehand and exchange specifications or a contract if necessary. If anything is unclear, contact your nearest sales branch.

## Limited warranty and Disclaimer/Compliance Requirements

The product used is subject to the following "Limited warranty and Disclaimer" and "Compliance Requirements". Read and accept them before using the product.

### Limited warranty and Disclaimer

**1. The warranty period of the product is 1 year in service or 1.5 years after the product is delivered.**

**Note 2)**

Also, the product may have specified durability, running distance or replacement parts. Please consult your nearest sales branch.

**2. For any failure or damage reported within the warranty period which is clearly our responsibility, a replacement product or necessary parts will be provided. This limited warranty applies only to our product independently, and not to any other damage incurred due to the failure of the product.**

**3. Prior to using POWER-GENEX products, please read and understand the warranty terms and disclaimers noted in the specified catalogue for the particular products.**

### Compliance Requirements

**1. The use of POWER-GENEX products with production equipment for the manufacture of weapons of mass destruction (WMD) or any other weapon is strictly prohibited.**

**2. The exports of POWER-GENEX products or technology from one country to another are governed by the relevant security laws and regulations of the countries involved in the transaction. Prior to the shipment of a POWER-GENEX product to another country, assure that all local rules governing that export are known and followed.**



## Precautions 1

Be sure to read before handling.

### Operation



#### Warning

1. Do not operate the valve monitoring controller outside the specified range as this may cause problems. (Refer to the specifications.)
2. Design the system to include a safety circuit to avoid the risk of danger should the valve monitoring controller suffer failure.
3. Be sure that exterior lead-in wiring to the terminal box is based on the guidelines for explosion-protection of manufactory electric equipment when being used as a flame proof, explosion proof construction.
4. Do not remove terminal cover in a hazardous location while the power is on.
5. Covers for the terminal and body should be in place while operating.
6. When using as an intrinsically safe explosion-proof product, do not wire in a hazardous location while the power is on.



#### Caution

1. Do not touch the actuator or valve's oscillating section when supply pressure has been added, as this is dangerous.
2. Make sure fingers do not get caught when mounting and aligning the cam.  
Cut off the pressure supply and always release the compressed air inside the valve monitoring controller and actuator before performing this work.
3. Always use with the body cover unit mounted.  
Moreover, the valve monitoring controller may not meet degrees of protection IP66 depending on the body cover mounting conditions. In order to meet degrees of protection IP66, tighten threads using the proper tightening torques (2.8 to 3.0 N·m).
4. Always flush the pipe's inside before piping to ensure foreign objects such as machining chips do not enter the positioner.
5. The actuator opening may become unstable when using the booster relay.
6. Always use a ground connection to prevent noise from the input current and to prevent damage because of static electricity.

### For users



#### Caution

1. Assemble, operate and maintain the valve monitoring controller after reading the operation manual thoroughly and understanding the content.



## Precautions 2

Be sure to read before handling.

### Handling



#### Caution

1. Avoid excessive vibration or impact to the valve monitoring controller body and any excessive force to the armature, as these actions may cause damage to the product. Handle carefully while transporting and operating.
2. If being used in a place where vibration occurs, using a binding band is recommended to prevent broken wires because of the vibration.
3. When exposed to possible moisture invasion, please take the necessary measures. For example, if the valve monitoring controller is left onsite for long periods, a plug should be put in the piping port and a body cover unit fitted to avoid water penetration.  
Take measures to avoid dew condensation inside the valve monitoring controller if exposed to high temperature and humidity. Take enough measures against condensation especially when packing for export.
4. Keep magnetic field off the valve monitoring controller, as this affects its characteristics.

### Air Supply



#### Caution

1. Use only dehumidified and dust extracted clean compressed air as the air supply.
2. Use only dehumidified and dust extracted clean compressed clean air as the valve monitoring controller contains extra fine spool and nozzle.  
Do not use a lubricator.
3. Do not use compressed air containing chemicals, organic solvents, salinity or corrosive gases, as this may cause malfunction.
4. When operating below the freezing point, protect the positioner from freezing.

### Operating Environment



#### Caution

1. Do not operate in locations with an atmosphere of corrosive gases, chemicals, sea water, or where these substances will adhere to the regulator.
2. Do not operate out of the indicated operation temperature range as this may cause damage to electronic parts and seal materials to deteriorate.
3. Do not operate in locations where excessive vibration or impact occurs.
4. If the body cover is being installed in a place where the body cover is exposed to direct sunlight, the use of a standard body cover is recommended.

## 2. Overview of Structure

This product consists of the following parts optionally.

- SPDT / DPDT / P&F NJ2-V3-N / P&F NJ2-12GM-N
- Potentiometer for position feedback
- Solenoid valve to operate the valve

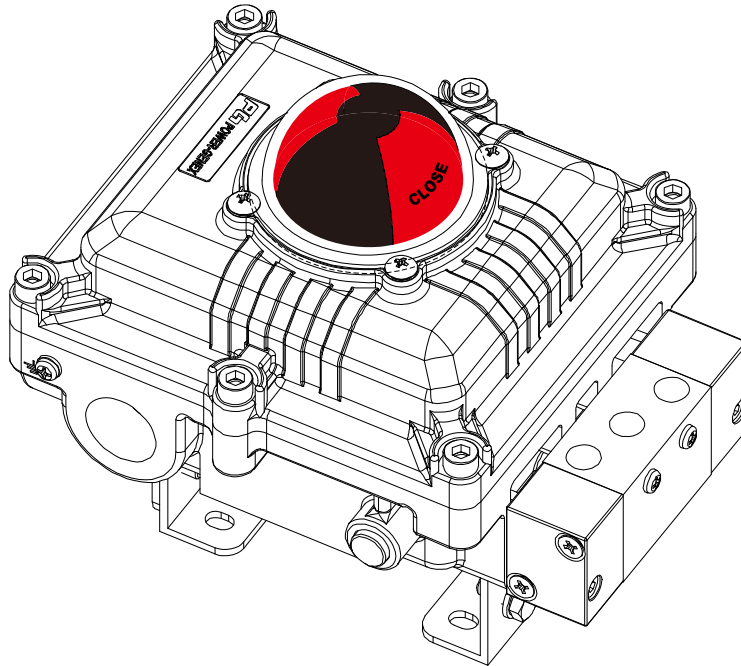

The followings are descriptions of internal parts without cover.

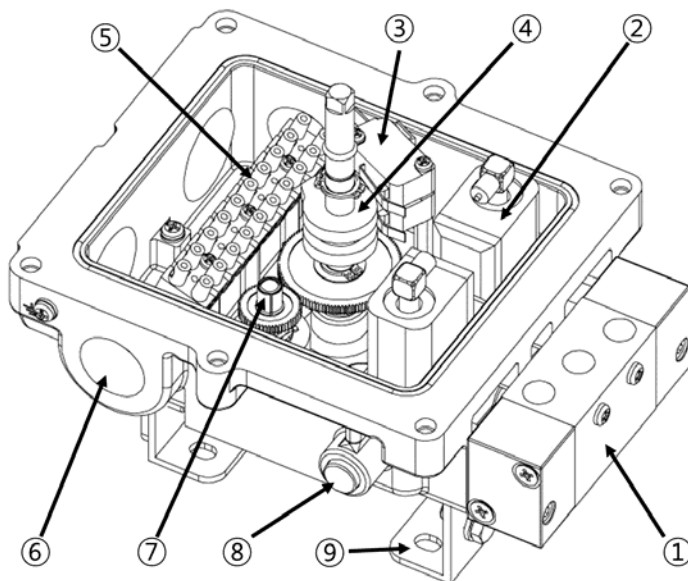

No.	Description
1	Solenoid valve
2	Solenoid coil
3	Switch / Sensor
4	Switch Cam
5	Terminal
6	Electrical Connections
7	Position Transmitter (Option)
8	Solenoid valve Auto / Manual Switch
9	Bracket

## 3. Specifications

		LSB - 7	LSB - 7S
Explosion proof / protection class		Ex d IIB+H <sub>2</sub> T6	
Solenoid Valve	Operating Air Pressure	Single Acting	1.5 ~ 9.9 kgf/cm <sup>2</sup>
		Double Acting	1.0 ~ 9.9 kgf/cm <sup>2</sup>
	Max. Supply Air Pressure	15 kgf/cm <sup>2</sup>	
	Supply Voltage	24VDC / 220VAC / 110VAC	
	Current	AC : 4.9VA(60Hz) / DC : 2.5W	
	Auto/Manual Mode	Button-push type	
	Response Time	Below 25ms	
	Coil Insulation Class	F – Class (Made in Germany / Nass)	
Max. Operating Frequency	5 cycle / second		
Ambient Temperature		-30°C ~ +75 °C	
Electrical connections		G 3/4, G 1/2, G 1, NPT 3/4, NPT 1/2, NPT 1, M20x1.5	
Pneumatic connections		Rc 1/4 or NPT 1/4	
Body material / painting		Aluminum diecast / powder coating	SUS 316
Weight		3 kg	5.8 kg

## 4. Description on Nameplate

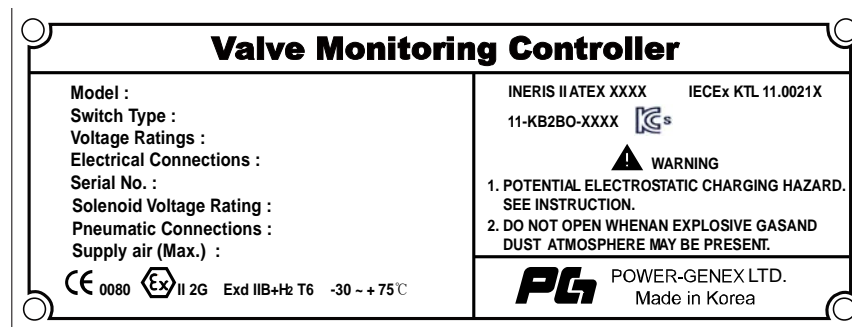

- .. MODEL NUMBER  
Model number and options are described.
- .. Switch Type : Mechanical switches / Proximity sensors type
- .. Voltage Ratings : switch / sensor voltage ratings
- .. Serial No. : A serial number and a manufacturing date for tracking are described.
- .. Solenoid Voltage Rating : Solenoid voltage(220VAC, 110VAC, 24VDC)
- .. Certificate No  
CE XXXX / INERIS ATEX XXXX / IECEx KTL 11.0021X / 11-KB2BO-XXXX
- .. Code : Ex d IIC T6 (Tamb. -30 to +75°C)
- .. WARNING
  1. Potential electrostatic charging hazard
  2. Do not open when an explosive gas and dust atmosphere may be present
  3. See instruction



## 5. Part Numbering System (order code)

		LSB	7	x	x	x	—	x	—	x	x	—	x	x	x	—	x	x
Body Material	Aluminum diecast	.																
	SUS 316	s																
Switch Type	Mechanical switches	0																
	Proximity switches	1																
Switch / Sensor	None	N																
	Mechanical switches	0																
	2 x SPDT	0																
	4 x SPDT	2																
	2 x DPDT	4																
	Proximity Sensors	6																
	2 x NJ2-V3-N / P&F	6																
	4 x NJ2-V3-N / P&F	7																
	2 x NJ2-12GK-N / P&F	8																
	4 x NJ2-12GK-N / P&F	9																
Position Transmitter	None	N																
	4 ~ 20mA output signal	O																
Coil Type	None	N																
	Single coil type	S																
	Double coil type	D																
Coil Power	None	N																
	220 VAC	A																
	110 VAC	B																
	24 VDC	C																
Indicator Option	2 – way (standard)	N																
	3 – way L-port	L																
	3 – way T-port	T																
Electrical Connections	2 x PF 1/2	A																
	2 x NPT 1/2	B																
	2 x M20	C																
	2 x PF 3/4	E																
	2 x NPT 3/4	F																
	2 x PF 1	H																
	2 x NPT 1	I																
Pneumatic Connections	Rc 1/4	R																
	NPT 1/4	N																
Feedback Shaft	Fork lever	F																
	NAMUR shaft (direct mounting)	N																
Mounting Bracket	None	N																
	Multi-size bracket for VDI/VDE3845 (IEC60534-6-2)	R																

## 6. Specifications of Switches and Proximity Sensors

### 6.1 Mechanical Switches

#### 6.1.1 SPDT, SZM-V16-2FA-61 (made by STARION)

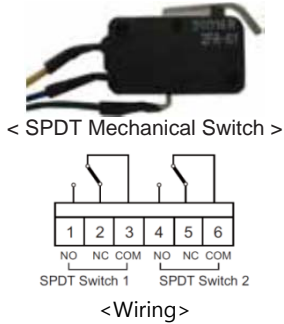

Type		Non-inductive load		Inductive load	
		Resistive	Lamp	Inductive	Motor
Rating	250VAC	16A	2A	10A	3A
	8VDC	16A	4A	10A	6A
	30VDC	10A	4A	10A	4A
	125VDC	0.6A	0.1A	0.6A	0.1A
	250VDC	0.3A	0.05A	0.3A	0.05A
Operating Temperature		-20°C ~ +105°C			

#### 6.1.2 DPDT, DZ-10G (made by OMRON)

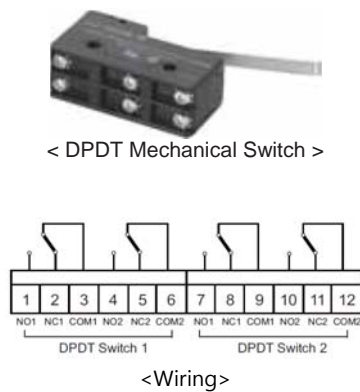

Type		Non-inductive load				Inductive load			
		Resistive		Lamp		Inductive		Motor	
		NO	NC	NO	NC	NO	NC	NO	NC
Rating	125VAC	10A	2A	1A	6A	3A	1.5A		
	250VAC	10A	1.5A	0.7A	4A	2A	1A		
	8VDC	10A	3A	1.5A	6A	5A	2.5A		
	14VDC	10A	3A	1.5A	6A	5A	2.5A		
	30VDC	10A	3A	1.5A	4A	3A	1.5A		
	125VDC	0.5A	0.5A	0.5A	0.05A	0.05A	0.05A		
	250VDC	0.25A	0.25A	0.25A	0.03A	0.03A	0.03A		
Operating Temperature		-20°C ~ +80°C							

### 6.2 Proximity Sensors

#### 6.2.1 NJ2-V3-N (made by Pepperl & Fuchs)

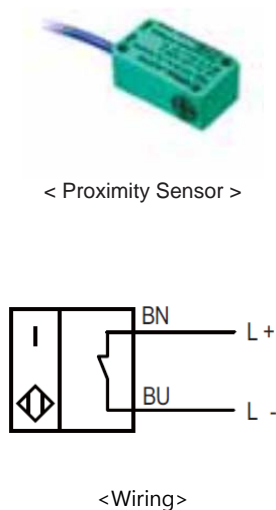

<b>General Specifications</b> Switching element function Rated operating distance Installation Output polarity Assured operating distance	NAMUR NC 2mm embeddable NAMUR 0 ~ 1.62 mm
<b>Nomial Ratings</b> Nominal voltage Switching frequency Hysteresis Current consumption Mesasuring plate not detected Measuring plate detected	8.2 VDC 0 ~ 1000 Hz 0.01 ~ 0.1 mm > 3mA < 1mA
<b>Mechanical Specifications</b> Connection type Core cross-section Housing material Sensing face Protection degree	Cable PCV, 130 mm 0.14 mm PBT PBT IP67
<b>Operating Temperature</b>	-25°C ~ +100°C

## 6.2.2 NJ2-12GK-N (made by Pepperl & Fuchs)



< Proximity Sensor >

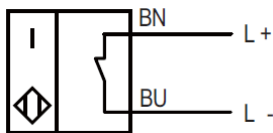

<Wiring>

<b>General Specifications</b> Switching element function Rated operating distance Installation Output polarity Assured operating distance	NAMUR NC 4mm Not embeddable NAMUR 0 ~ 3.24 mm
<b>Nominal Ratings</b> Nominal voltage Switching frequency Hysteresis Current consumption Measuring plate not detected Measuring plate detected	8.2 VDC 0 ~ 1500 Hz 3% > 3mA < 1mA
<b>Mechanical Specifications</b> Connection type Core cross-section Housing material Sensing face Protection degree	Cable PCV, 2 m 0.34 mm PBT PBT IP66
<b>Operating Temperature</b>	-25°C ~ +100°C

## 7. Specifications of Position Transmitter

<b>General Specifications</b> Current Output Signal Power Supply Range Span Adjustable Angle	4 ~ 20mA , 2-wire 12 ~ 30VDC (24VDC recommendable) 0 ~ 120°
<b>Nominal Ratings</b> Linearity Repeatability Hysteresis	Within ± 1.0% F.S. Within ± 0.25% F.S. Within ± 1.0% F.S.
<b>Operating Temperature</b>	-20°C ~ +70°C

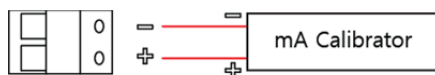

<with mA calibrator>



<with mA tester>

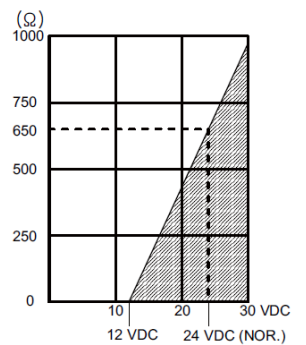

Transmitter Load Limitation

## 8. Operating Principle of Solenoid Valve

<Power On / Action>

<Power Off / Normal>

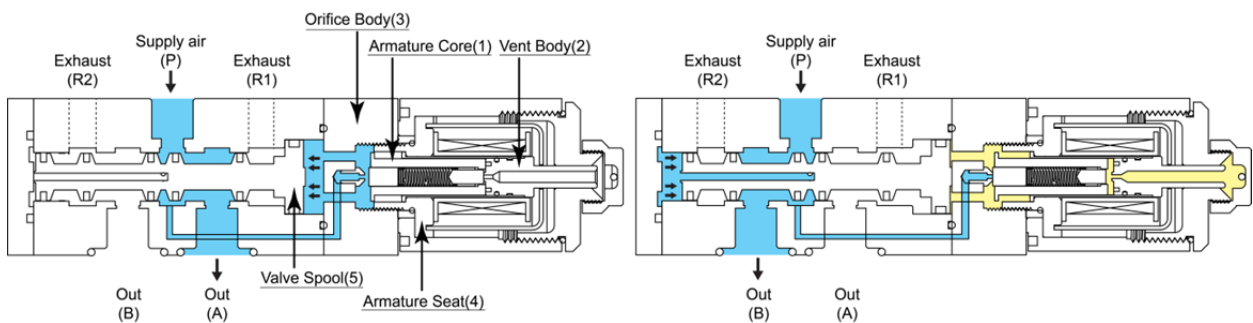

- 1) If the rated voltage/current is supplied to the solenoid valve, the magnetic force around coils is generated.
- 2) According to the magnetic force, the armature core (1) reaches the vent body (2) and blocks the vent air line.
- 3) The supply air (P) pushes the spool through the orifice body (3) and vents out from A.
- 4) If the solenoid valve is powered off, the magnetic force around coils vanishes.
- 5) Air from the orifice body (3) is blocked by the spring between the armature seat (4) and the armature core.
- 6) The supply air pushes the spool (5) from the bottom of the solenoid valve through the air line located at the center of the spool, and the remaining air inside of the orifice body (3) vents out from the vent body (2).

### 8.1 Manual Button on Solenoid Valve

While air is supplied, the solenoid valve can be operated manually with a button. If the Auto / Manual button is pushed, the output port A becomes open.

Note that the Auto/Manual button is not available while a power is supplied

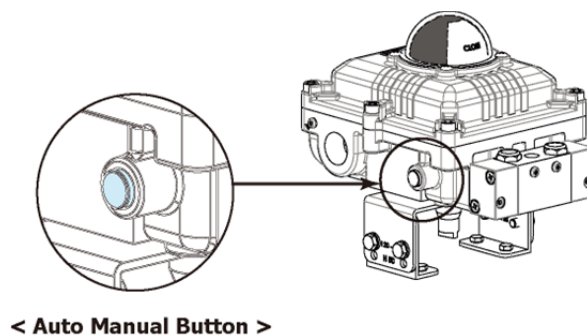
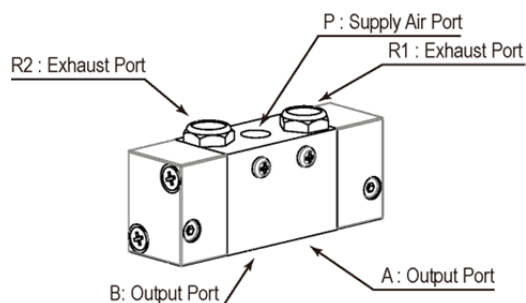

9. Installation

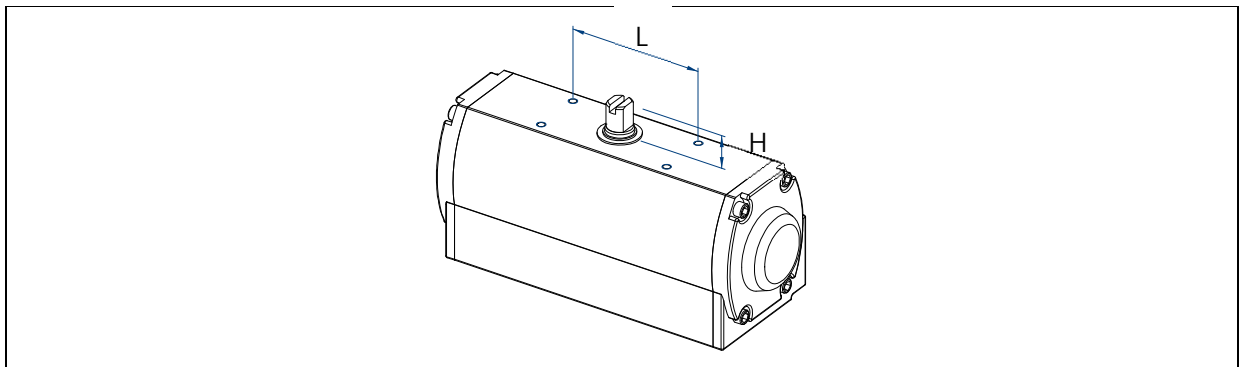
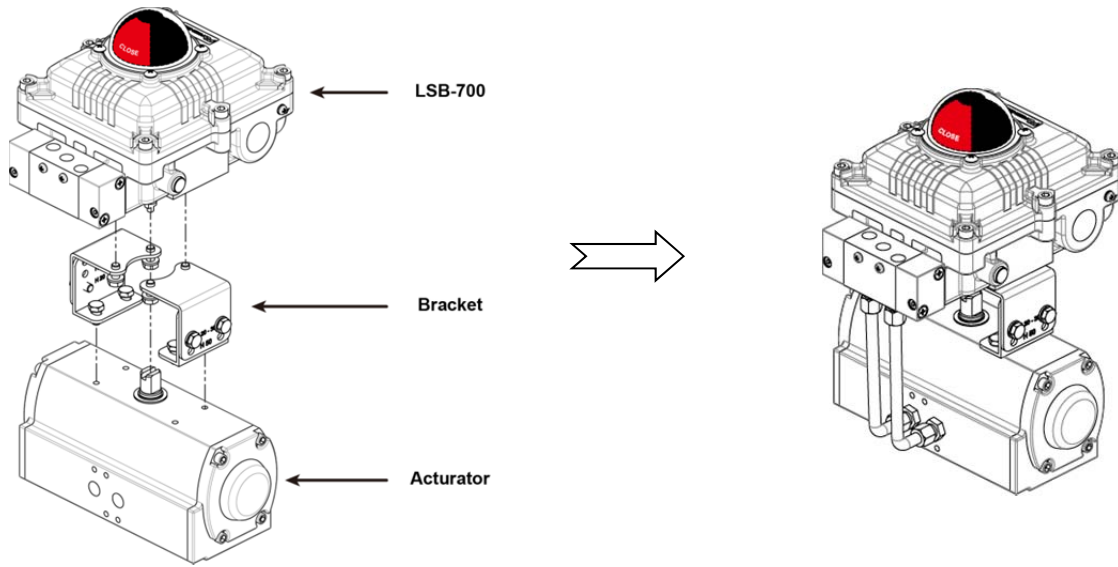

L (mm)	H (mm)		L (mm)	H (mm)	
80	20		130	20	
80	30		130	30	
80	30		130	30	
80	50		130	50	
80	50		130	50	

## 10. Electrical Connections



- ① Be sure to supply the rated voltage and current stated on this manual. Otherwise, it may cause a serious damage or malfunctions.
- ② Check polarity of + and – exactly and connect wires.
- ③ When it is necessary to open the positioner cover at a humid place, more attention is required. It may cause a serious damage or malfunctions.

IECEX explosion-proof construction

LSB-7 becomes explosion proof, as certified by IECEX, according to the model selected.

The explosion-proof grade has the following approval : Ex d IIB+H2 T6.

Take extra care when handling the LSB-7 as explosion-proof equipment

To use as Ex d IIB+H2 T6

A) Pressure-proof packing.

As shown below in the chart, use "Cable gland"

B) Metal Piping.

Attach the sealant fitting bracket near the cable port.

(For details, refer to "The guideline on electric equipment explosion proof" published by the Technology Institution of Industrial Safety).

### • 2 x SPDT, single coil

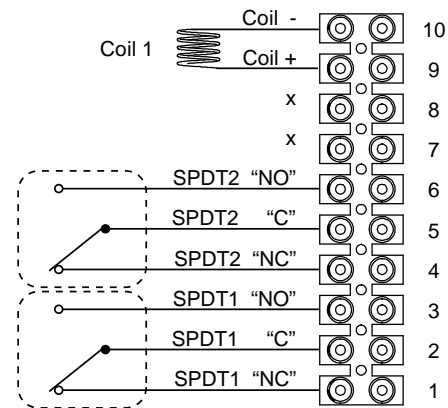
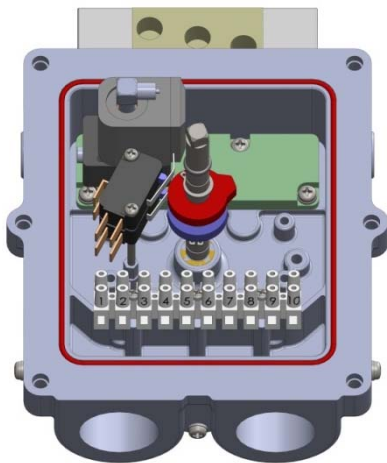

### • 2 x DPDT, single coil

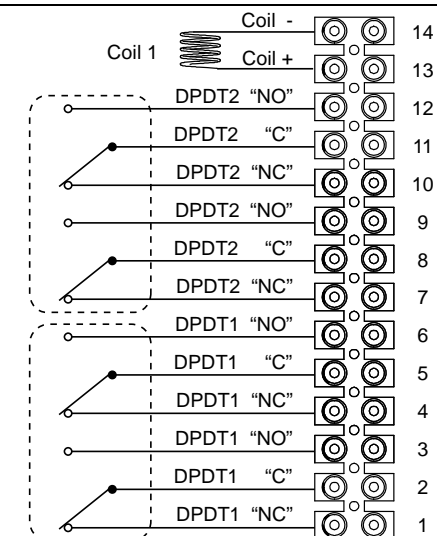
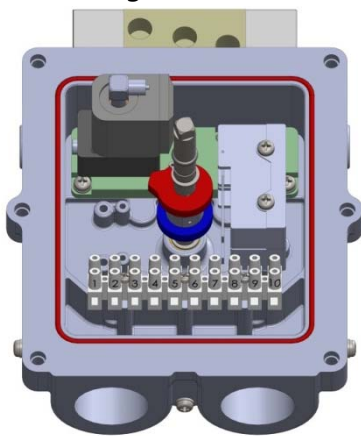

- 2 x P&F NJ2-V3-N, single coil

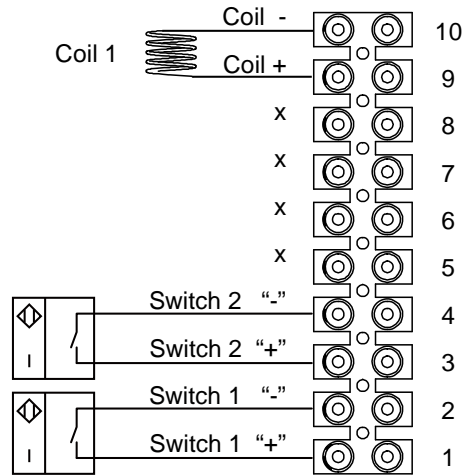
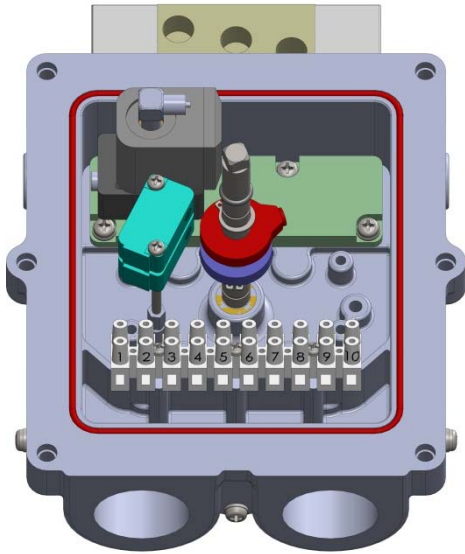

- 2 x P&F NJ2-12GK-N, single coil

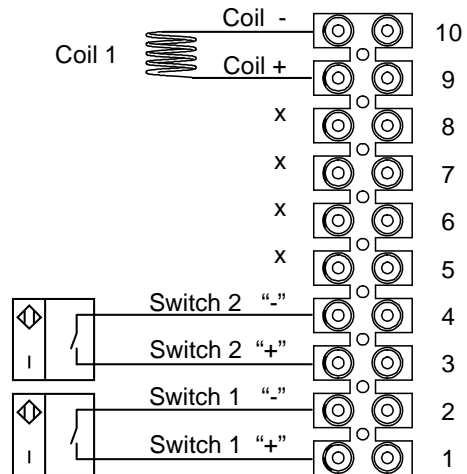
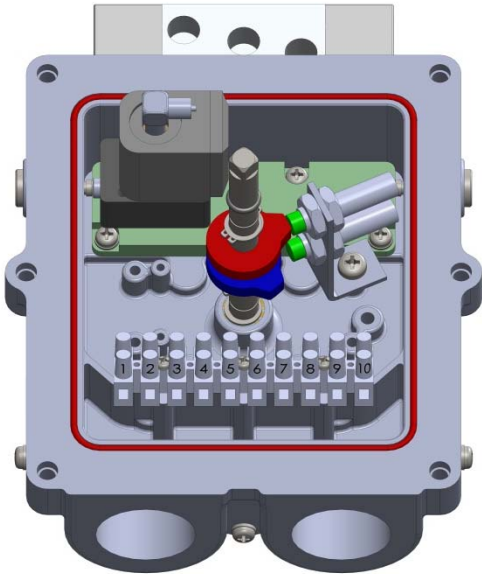

## - Position Transmitter Option

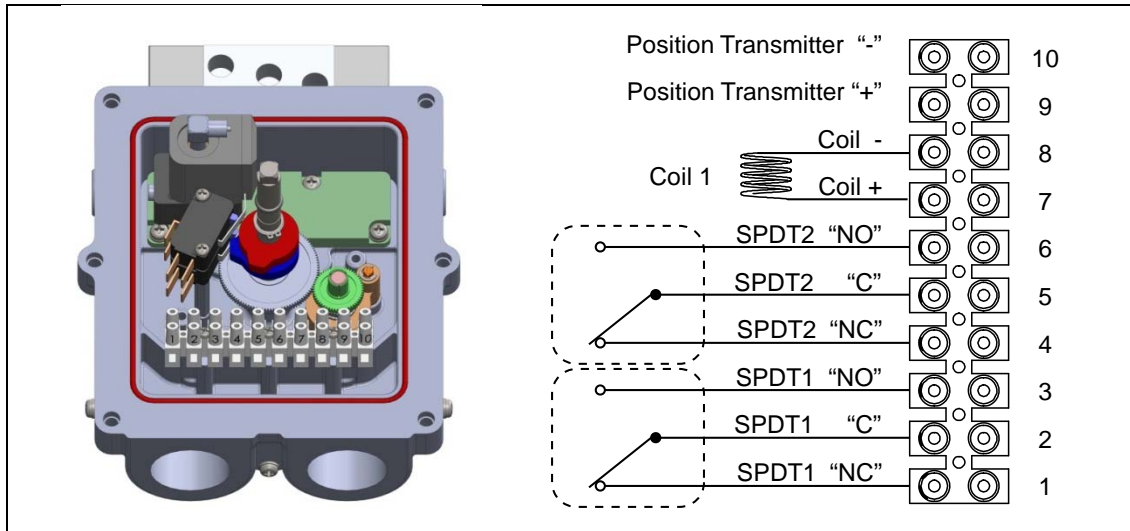

<2 x SPDT single coil + Position transmitter>



- ① It is necessary to set Zero and Span of position transmitter manually.
- ② The power supply of 12 – 30VDC should be supplied.

a) With mA loop calibrator

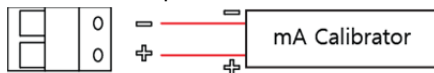

b) With multi-meter

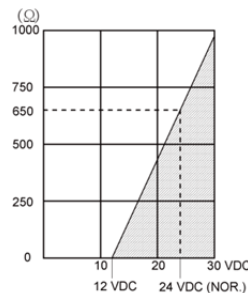
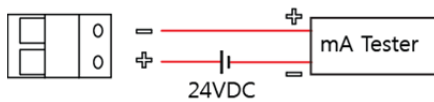

Transmitter Load Limitation

c) Setting



- Install the LSB-7 properly before setting the position transmitter.
  - Check the proper position of the RA/DA switch before setting.
1. Turn the Zero screw until the output signal reaches 4mA.
  2. Turn the Span screw until the output signal reaches 20mA.
  3. Repeat the above procedure until the output signals reach 4mA and 20mA.
  4. Operate the valve and check if the output signals are transmitted properly.

### 10.1 Earthing

The Positioner must be connected to a good quality earth. The units are provided with internal and external earthing terminals which are both located on the terminal chamber section of the unit

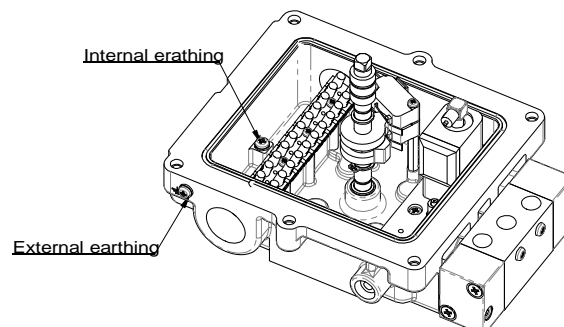



## 11. Setting of Cams and Switches

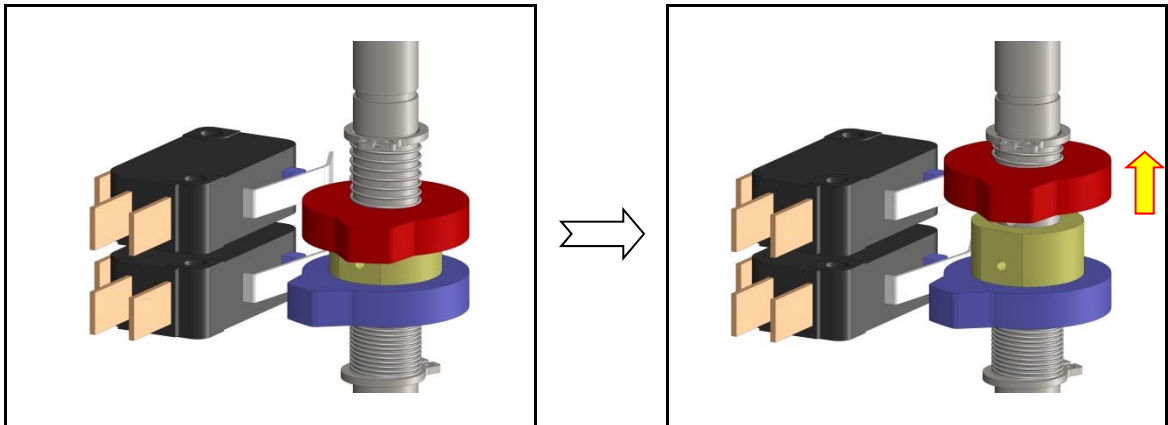

a) Push up the red cam if it is necessary to set the position of the red cam.

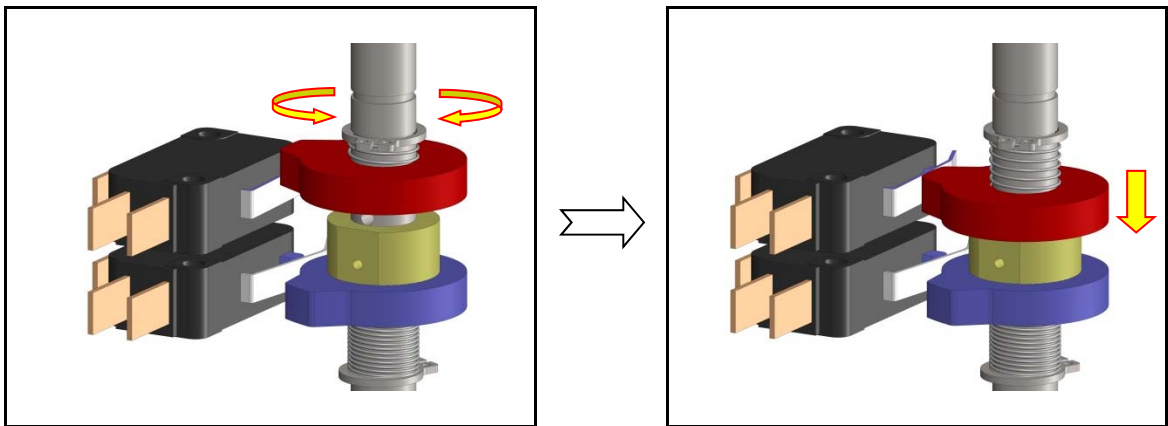

b) Turn the red cam until it touches the limit switch. And put down and fix it with a wrench bolt.

c) Do the same procedure for setting of the blue cam. But push it down to move.

12. Dimensions

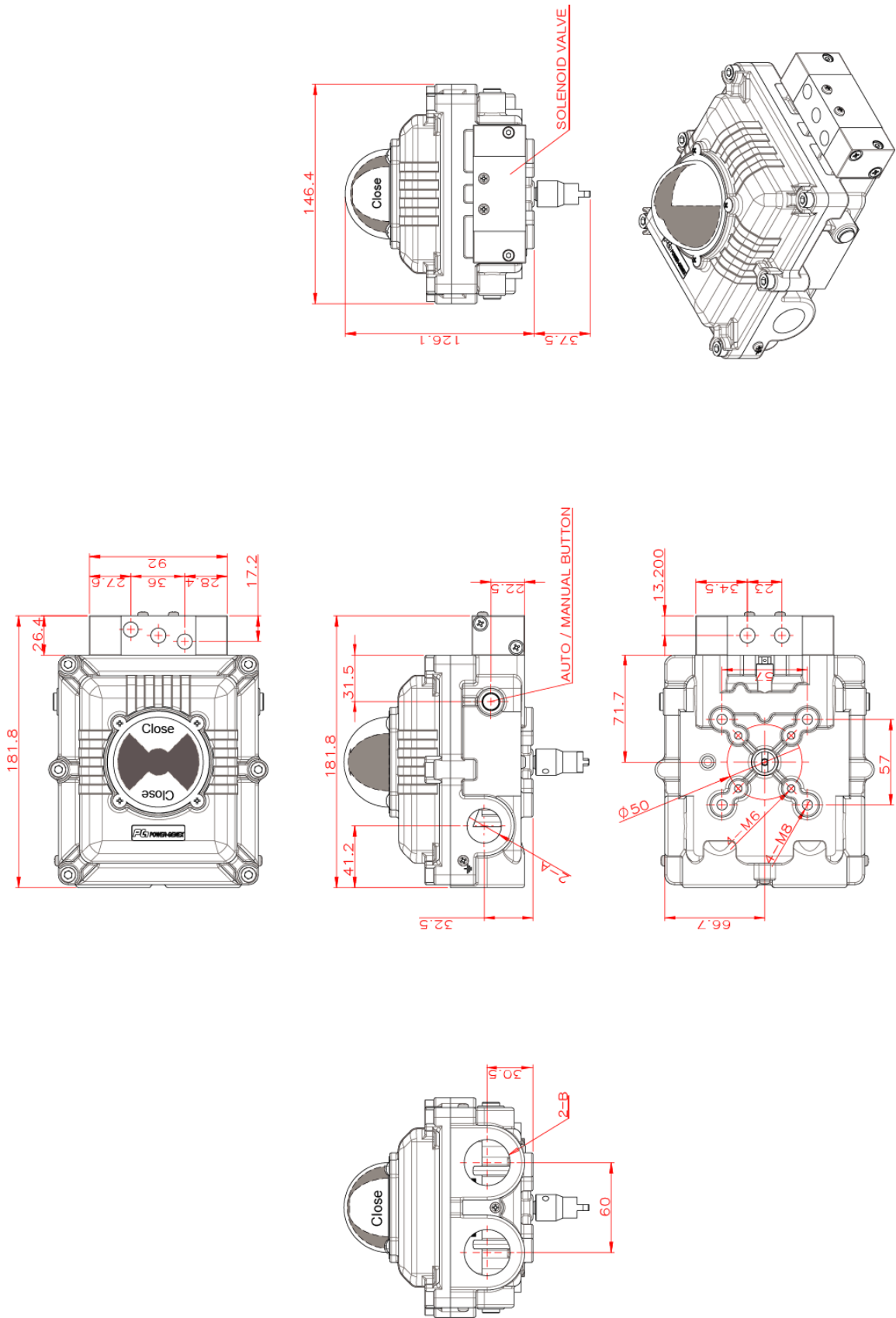

 **Power-Genex Ltd.**

44B9L, 434-9, Nonhyun-dong, Namdong-gu, Incheon 405-849 Korea

Tel : +82-32-812-6644

Fax : +82-32-812-6645

Website : <http://www.powergenex.com>

E-mail : [sales@powergenex.com](mailto:sales@powergenex.com)

Subject to change without prior notice