

# HP 60 series

HP60/I/E

07 | 2016

**PNEUMATIC & ELECTRIC CONTROL and ON-OFF VALVES  
SINGLE SEAT TWO WAY 600 Class LOW NOISE and ANTI-CAVITATION**

**VALVOLE DI REGOLAZIONE e ON-OFF PNEUMATICHE ed ELETTRICHE  
SEGGIO SINGOLO DUE VIE classe 600 ANTIRUMORE e ANTICAVITAZIONE**



## **TYPE - TIPO HP60 RA**

**Pneumatic version**  
**Normally close – air opens**  
Versione pneumatica  
Normalmente chiusa – aria apre

## **TYPE - TIPO HP60 DA**

**Pneumatic version**  
**Normally open – air closes**  
Versione pneumatica  
Normalmente aperta – aria chiude

## **TYPE - TIPO HP60 EP**

**Electric version**  
**Tension opens and closes**  
Versione elettrica  
Tensione apre e chiude

**High Performance - Alte Prestazioni**

**PED 2014/68/UE**

MODULE A2 – MODULO A2  
CE 1214

**ATEX 2014/34/UE**

II 2 G/D Tx CE 0398  
TYPE - TIPO HP60 RA / HP60 DA

**TA-Luft 07/2002 – VDI 2440 11/2000 Approved**

Page – pagina 1 / 39

**CONFLOW** s.p.a.

FLOW CONTROL SOLUTIONS

COMPANY WITH  
QUALITY SYSTEM  
CERTIFIED BY DNV GL  
= ISO 9001 =

Via Lecco, 69/71  
20864 AGRATE BRIANZA (MB)  
Tel. 039/651.705 - 650.397  
Fax 039/654.018  
e-mail:sales@conflow.it  
e-mail:vendite@conflow.it  
www.conflow.it

# HP 60 Series

## DESCRIPTION

HP 60 series are with a straight body single seat class ANSI 600, with cage guided balanced plug or contoured plug designed to withstand the most severe process conditions.

On cage version the flow is mainly controlled by the special drilled cage, which acts as a continuous and full plug guide along the whole valve travel.

The special plug design allows improving valve rangeability by reducing minimum controllable flow and plug erosion.

The high pressure recovery factor value on cage system compared with contoured plug ensure higher flow rate on compressible fluid service and reduces cavitation risk and effects on liquid service.

All versions have quick change trim.

There are different versions :

Microflow passages on Ø 1".

Contoured unbalanced plug from Ø 1" to Ø 2"

Simple-Double-Triple cage unbalanced plug Ø 1"

Simple-Double-Triple cage balanced plug > Ø 1".

On request all reduced bores are available

Bonnet style, finned and extended is specially designed to comply with all working conditions.

All valves can be equipped by CONFLOW pneumatic control or on-off diaphragm actuators spring return or electric control and on-off actuators tension opens & closes.

## MAIN FEATURES

- *Size* from DN 1" to DN 4"  
Wide operating temperature – 45 °C to + 425 °C  
Up to – 196 °C with optional special extended bonnet
- *Ratings*  
ANSI 600 according ASME B16.34  
PN 63 – PN 100 according EN 12516-1
- *Standard Connections*  
ANSI B16.5 - 600 RF – RJ  
EN1092-1 PN 63 form B-C-D-E-F  
EN 1092-1 PN 100 form B-C-D-E-F  
On request :  
ANSI B16.5 -150 / 300 RF – RJ  
BW ANSI B16.25  
SW up to Ø 2"
- *Finned bonnet as base*  
On request extended type for low temperature < - 45 °C  
On request bellows seal PN100 for dangerous fluids
- *Stem Packing*  
PTFE "V" rings up to 190 °C ( Approvato TA-Luft su ric. )  
PTFE/GR "V" rings up to 220 °C  
( 85% PTFE + 15% GRAPHITE )  
PURE GRAPHITE up to 300 °C (over 270 °C with lubricator )
- *Special stem packing*  
PURE GRAPHITE with labyrinth and lubricator up to 427 °C
- *Trim quick change – seat & plug with satellite Gr. 6*
- *Leakage class ANSI B16.104 std class IV°*  
On request class V° and class VI°

## DESCRIZIONE

La serie HP 60 è costruita con corpo a globo seggio singolo via diritta classe ANSI 600 , trim a gabbia con pistone bilanciato o otturatore parabolico, è consigliata per severe condizioni di processo industriale.

Nella versione a gabbia il fluido è controllato da uno o più stadi multiforo che guidano costantemente il pistone lungo tutta la corsa.

La configurazione particolare del trim consente alti valori di "rangeability" riducendo anche i fenomeni di erosione degli interni.

Il fattore di recupero dell'alta pressione sul sistema trim a gabbia in comparazione con gli otturatori parabolici assicura una più alta portata su fluidi comprimibili e riduce i rischi legati alla cavitazione sui liquidi.

Tutte le versioni dispongono del sistema cambio veloce del "trim" – interno.

Sono disponibili diverse versioni :

Otturatori microflusso su Ø 1"

Otturatore parabolico da Ø 1" a Ø 2"

Semplice – Doppia – Tripla gabbia con pistone non bilanciato su Ø 1"

Semplice – Doppia – Tripla gabbia con pistone bilanciato da Ø 1.1/2" fino a Ø 4".

A richiesta sono disponibili i passaggi ridotti.

La configurazione del bonnet è del tipo esteso – alettato di serie in grado di lavorare in tutte le condizioni di esercizio previste dal rating.

Tutte le valvole sono equipaggiate con attuatori pneumatici a diaframma di regolazione con molla di ritorno ed on-off originali CONFLOW e con attuatori elettrici tensione apre e chiude.

## CARATTERISTICHE PRINCIPALI

- *Diametri* da DN 1" a DN 4"  
Ampia gamma di temperature di esercizio da -45 °C a + 425 °C  
fino a – 196 °C con prolunga allungata speciale
- *Ratings*  
ANSI 600 secondo ASME B16.34  
PN 63 – PN 100 secondo EN 12516-1
- *Connessioni standard*  
ANSI B16.5 - 600 RF - RJ  
EN 1092-1 PN 63 forma B-C-D-E-F  
EN 1092-1 PN 100 forma B-C-D-E-F  
A richiesta :  
ANSI B16.5 – 150 / 300 RF - RJ  
BW ANSI B16.25  
SW fino a Ø 2"
- *Bonnet alettato di serie*  
A richiesta bonnet allungato per basse temperature < - 45 °C  
A richiesta prolunga con soffiato PN100 per fluidi pericolosi
- *Premistoppa*  
PTFE "V" rings fino a 190 °C ( TA-Luft Approved on request )  
PTFE/GR "V" rings fino a 220 °C  
( 85% PTFE – 15% GRAFITE PURA )  
GRAFITE PURA fino a 300 °C (sopra 270 °C con lubrificatore)
- *Premistoppa Speciale*  
GRAFITE PURA con labirinto e lubrificatore fino a 427 °C
- *Interni* con cambio veloce – sede e otturatore stellati Gr. 6
- *Classificazione perdite* ANSI B16.104 classe IV°  
A richiesta classe V° - classe VI°

# HP 60 Series

CODE SYSTEM *Body Group* – CODIFICA *Gruppo Corpo*

HP	040	B	60R	FB	CPL	G	
<b>Series - Serie</b>	025 = DN 25	B = A216WCB	6B = PN63 form B	FB = full bore pass.pieno	1L = linear simple cage gabbia semp. lineare	T = PTFE packing PTFE premistoppa	
	040 = DN 40	C = A351 CF8M	6C = PN63 form C	01 = Ø 1/8"	2L = linear double cage gabbia doppia lineare	R = PTFE/GR packing PTFE/GR premistoppa	
	050 = DN 50	L = A352 LCB	6D = PN63 form D	02 = Ø 3/16"	3L = linear triple cage gabbia tripla lineare	G = Graphite packing Premistoppa Grafite	
	065 = DN 65	D = A351 CF3M	6E = PN63 form E	03 = Ø 1/4"	1E = equiperc. simple cage gabbia semplice EQP	I = Graphite + lubrificator Grafite + Ingrassatore	
	080 = DN 80	Y = special material material spec.	6F = PN63 form F	04 = Ø 3/8"	2EL = 1 <sup>st</sup> EQP - 2 <sup>nd</sup> LIN 1° EQP - 2 <sup>nd</sup> LIN	L = Graphite + labyrinth + lub. Grafite + labirinto + Ingra.	
	100 = DN 100		1B = PN100 form B	05 = Ø 1/2"	3EL = 1 <sup>st</sup> EQP-2/3 <sup>rd</sup> LIN 1° EQP-2/3 <sup>rd</sup> LIN	E = Extended PTFE Allungato PTFE	
			1C = PN100 form C	06 = Ø 3/4"	CPL = Contoured linear Lineare profilato ≤ DN 50	U = Bellows PN100 + PTFE Packing Soffietto PN100 e PTFE	
			1D = PN100 form D	07 = Ø 1"	CPE = Contoured % EQP profilato ≤ DN 50	F = PTFE packing TA-LUFT Prem. PTFE TA-LUFT	
			1E = PN100 form E	08 = Ø 1.1/2"	CPT = Quick opening Apertura rapida ≤ DN 50	U = Bellows PN100 + PTFE Packing Soffietto PN100 e PTFE	
			1F = PN100 form F	09 = Ø 2"	MFP = Contoured linear Lineare profilato ≤ Ø 3/8"	V = Bellows PN100 + PTFE/GR Packing Soff. PN100 e PTFE/GR	
			6LT = ANSI 600 Large Tongue	15R = ANSI 150 RF	10 = Ø 2.1/2"	1SG = Contoured % 1 milling EQP profilato 1 sg. Ø 3/8" - Ø 1/4"	Z = Bellows PN100 + Graphite Packing Soffietto PN100 e Grafite
			6LG = ANSI 600 Large Groove	15J = ANSI 150 RJ	11 = Ø 3"	2SG = Contoured % 2 milling EQP profilato 2 sg. Ø 3/8" - Ø 1/4"	
			6ST = ANSI 600 Small Tongue	30R = ANSI 300 RF			
			6SG = ANSI 600 Small Groove	30J = ANSI 300 RJ			
			6LM = ANSI 600 Large Male	60R = ANSI 600 RF			
			6LF = ANSI 600 Large Female	60J = ANSI 600 RJ			
			6SM = ANSI 600 Small Male	SW = socket welding			
			6SF = ANSI 600 Small Female	BW = but welding			
						<b>Additional code for Guide bushing</b>	<b>Codici aggiuntivi per bussole guida</b>
						HP025050STGB = Stellite on guide bushing CP trim DN 25 / 50	
					HP025100STGB = Stellite on guide bushing 1L/3L/1EL/3EL trim DN 25 / 100		
					HP025TIGB = S.S. A316 Ti guide bushing CP trim DN 25		
					HP040050TIGB = S.S. A316 Ti guide bushing CP trim DN 40/50		
					HP025100TIGB = S.S. A316 Ti guide bushing 1L/3L/1EL/3EL trim DN 25 / 100		

# HP 60 Series

CODE SYSTEM Soft Seal cl. VI° – CODIFICA Tenuta Morbida cl. VI°

HP	025	316	MFP			T
<b>Series - Serie</b>	025 DN 25	025 = Full Bore Ø 1" Passaggio Pieno Ø 1"	1L	2L	3L	T PTFE cl.V I° soft seal tenuta Morbida
			1E	2EL	3EL	
			CPL	CPE	CPT	
		020 = Reduced Bore Ø 3/4" Passaggio Ridotto Ø 3/4"	CPL	CPE	CPT	
			015 = Reduced Bore Ø 1/2" Passaggio Ridotto Ø 1/2"	CPL	CPE	
		038 = Reduced Bore Ø 3/8" Passaggio Ridotto Ø 3/8"		MFP	1SG	
			014 = Reduced Bore Ø 1/4" Passaggio Ridotto Ø 1/4"			
	0316=Reduced Bore Ø 3/16" Passaggio Ridotto Ø 3/16"	MFP				
		018 = Reduced Bore Ø 1/8" Passaggio Ridotto Ø 1/8"	MFP			
	040 DN 40		040 = Full Bore Ø 1.1/2" Passaggio Pieno Ø 1.1/2"	1L	2L	
		CPL		CPE	CPT	
		025 = Reduced Bore Ø 1" Passaggio Ridotto Ø 1"	1L	2L	3L	
	CPL		CPE	CPT		
	050 DN 50	020 = Reduced Bore Ø 3/4" Passaggio Ridotto Ø 3/4"	CPL	CPE	CPT	
			050 = Full Bore Ø 2" Passaggio Pieno Ø 2"	1L	2L	
		040 = Reduc. Bore Ø 1.1/2" Passaggio Rid. Ø 1.1/2"		1L	2L	
	025 = Reduced Bore Ø 1" Passaggio Ridotto Ø 1"		CPL	CPE	CPT	
		065 DN 65	065 = Full Bore Ø 2.1/2" Passaggio Pieno Ø 2.1/2"	1L	2L	
	1E			2EL	3EL	
	050 = Reduced Bore Ø 2" Passaggio Ridotto Ø 2"		1L	2L	3L	
			1E	2EL	3EL	
	040 = Reduc. Bore Ø 1.1/2" Passaggio Rid. Ø 1.1/2"		CPL	CPE	CPT	
			1L	2L	3L	
	080 DN 80	080 = Full Bore Ø 3" Passaggio Pieno Ø 3"	1L	2L	3L	
			1E	2EL	3EL	
		065 = Reduc. Bore Ø 2.1/2" Passaggio Ridotto Ø 2.1/2"	1L	2L	3L	
			1E	2EL	3EL	
		050 = Reduced Bore Ø 2" Passaggio Ridotto Ø 2"	1L	2L	3L	
			1E	2EL	3EL	
	080 = Full Bore Ø 3" Passaggio Pieno Ø 3"	CPL	CPE	CPT		
		100 DN 100	100 = Full Bore Ø 4" Passaggio Pieno Ø 4"	1L	2L	
	1E			2EL	3EL	
	080 = Reduced Bore Ø 3" Passaggio Ridotto Ø 3"		1L	2L	3L	
			1E	2EL	3EL	
	065 = Reduc. Bore Ø 2.1/2" Passaggio Ridotto Ø 2.1/2"		1L	2L	3L	
			1E	2EL	3EL	

The code of Soft Seal must be added to standard code of body group

Il codice della Tenuta Morbida va aggiunto al codice standard del gruppo corpo

# HP 60 Series

CODE SYSTEM s.s. stud bolts & nuts – CODIFICA prigionieri & dadi inox

HP	025	B8
<b>Series Serie</b>	025 = DN 25	<b>B8</b> = A304 <b>B8M</b> = A316
	040050 = DN 40/50	
	065080 = DN 65/80	
	100 = DN 100	

The code of s.s. stud bolts & nuts must be added to standard code of body group  
Il codice dei prigionieri e dadi inox va aggiunto al codice standard del gruppo corpo

CODE SYSTEM *Pneumatic Actuators* – CODIFICA *Attuatori Pneumatici*

HP	T4	C28	630	
<b>Series - Serie</b>	T2 = T250	C19 = stroke corsa	315 = 3-15 psi DA	(blanc) = std
	T3 = T310	C28 = stroke corsa	618 = 6-18 psi	X = s.s. bolts Viteria inox
	T4 = T400	C50 = stroke corsa	630 = 6-30 psi	
	T5 = T500		35 = 35 psi	

CODE SYSTEM *Electric Actuators* – CODIFICA *Attuatori Elettrici*

HPPSL	1	C28	C
<b>Series – Serie</b>	1 = PSL 201	C19 = stroke corsa	A = 220/230 V AC
	2 = PSL 202	C28 = stroke corsa	B = 110 V AC
	3 = PSL204	C50 = stroke corsa	C = 24 V AC
	4 = PSL210		D = 24 V DC
	5 = PSL214		E = 380/400 V AC
	6 = PSL320		
	7 = PSL325		

\* optional codes separate ( potentiometers – positioner – switches – electrical heater )

\* codici optionals a parte ( potenziometri – posizionatore – fine corsa – resistenza elettrica )

# HP 60 Series

Pressure and Temperature chart - Diagramma Pressioni Temp.

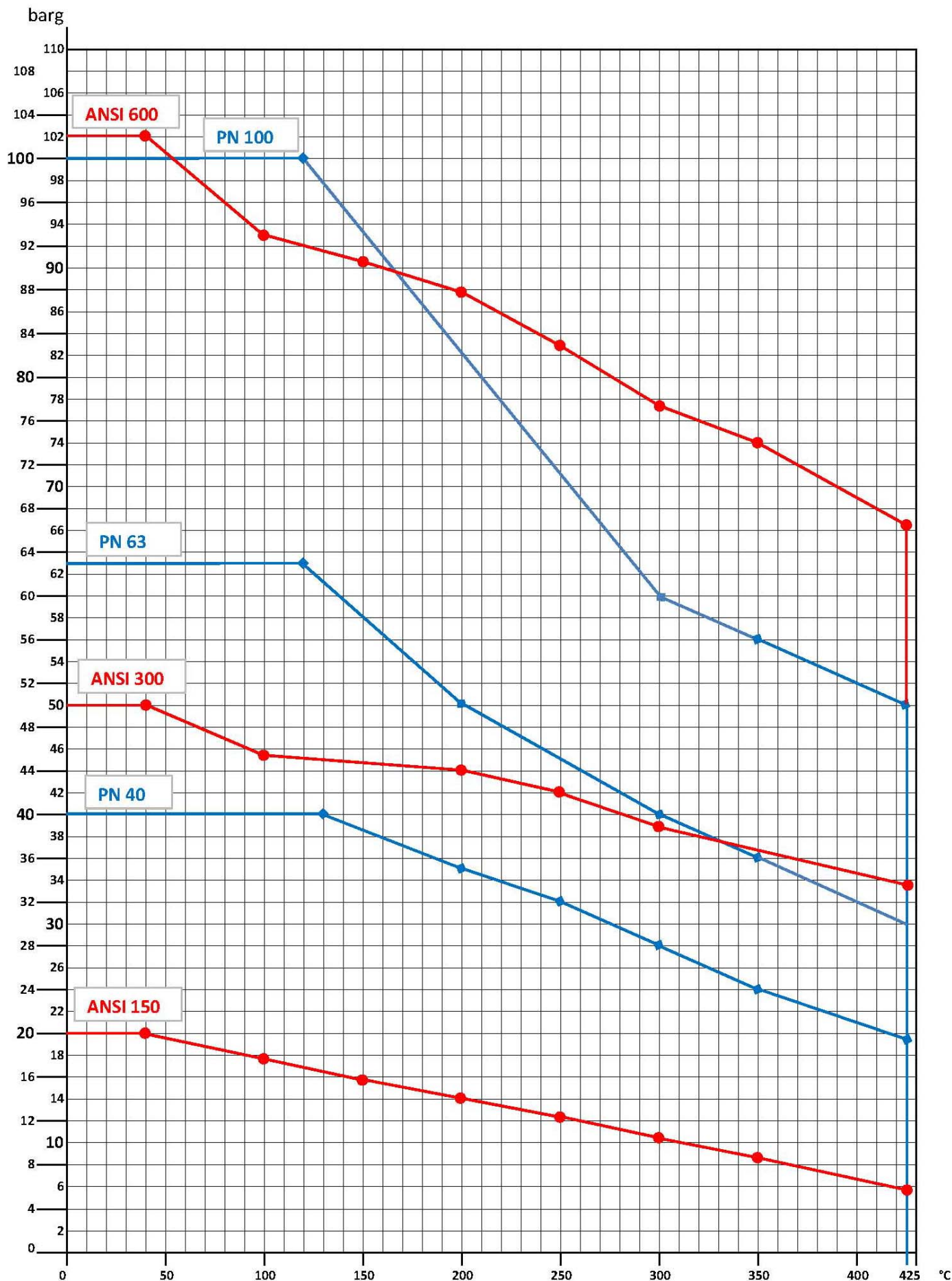

# HP 60 Series

CONFIGURATION BODY GROUP

Low Noise

CONFIGURAZIONE GRUPPO CORPO

Antirumore

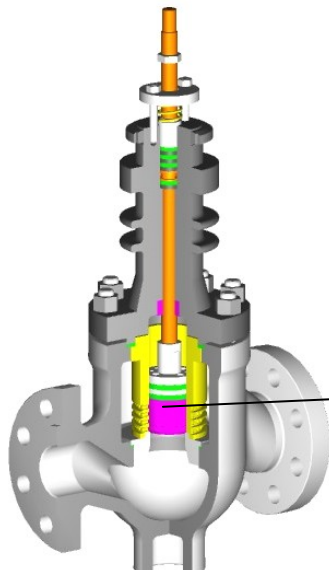

TRIM 1L

**LINEAR SIMPLE CAGE from DN 40 to DN 100 BALANCED**  
( DN 25 not balanced )

GABBIA SEMPLICE LINEARE dal DN 40 al DN 100 EQUILIBRATA  
( DN 25 non equilibrata )

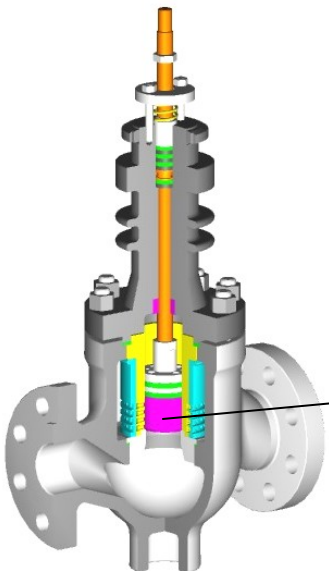
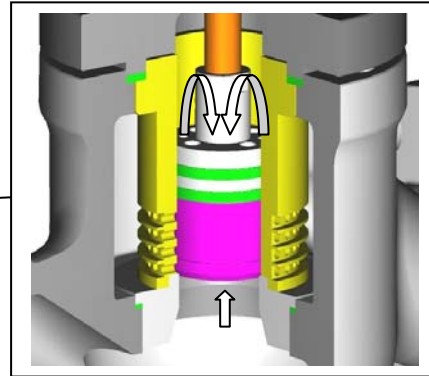

TRIM 2L

**LINEAR DOUBLE CAGE from DN 40 to DN 100 BALANCED**  
( DN 25 not balanced )

GABBIA DOPPIA LINEARE dal DN 40 al DN 100 EQUILIBRATA  
( DN 25 non equilibrata )

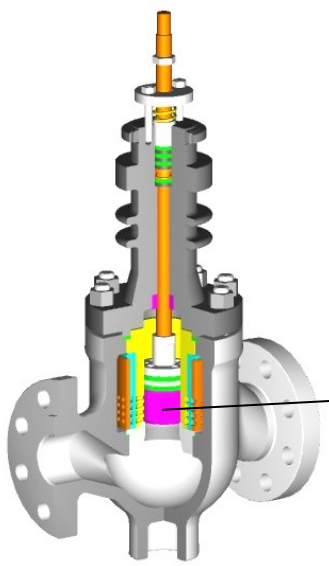
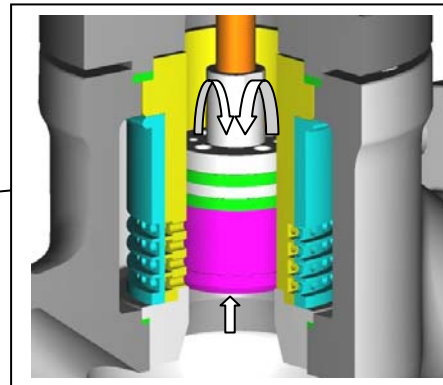

TRIM 3L

**LINEAR TRIPLE CAGE from DN 40 to DN 100 BALANCED**  
( DN 25 not balanced )

TRIPLICE GABBIA LINEARE dal DN 40 al DN 100 EQUILIBRATA  
( DN 25 non equilibrata )

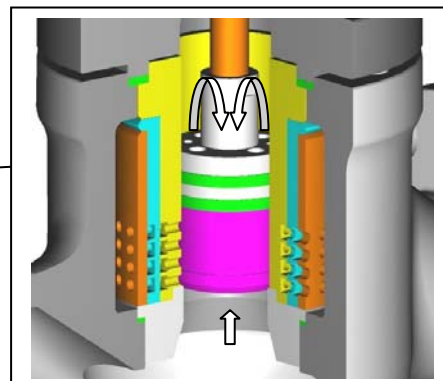

# HP 60 Series

CONFIGURATION BODY GROUP  
Low Noise

CONFIGURAZIONE GRUPPO CORPO  
Antirumore

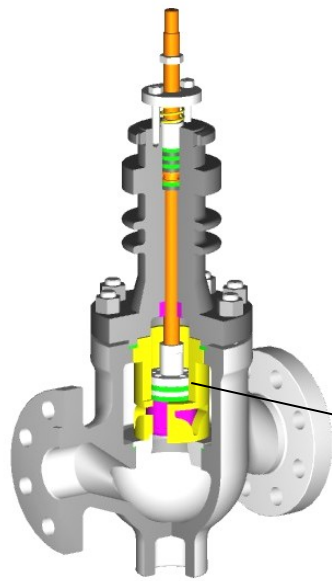

TRIM 1E

**EQUIPERCENTAGE SIMPLE CAGE**  
from DN 40 to DN 100 **BALANCED** ( DN 25 not balanced )

GABBIA SEMPLICE EQUIPERCENTUALE  
dal DN 40 al DN 100 **EQUILIBRATA** ( DN 25 non equilibrata )

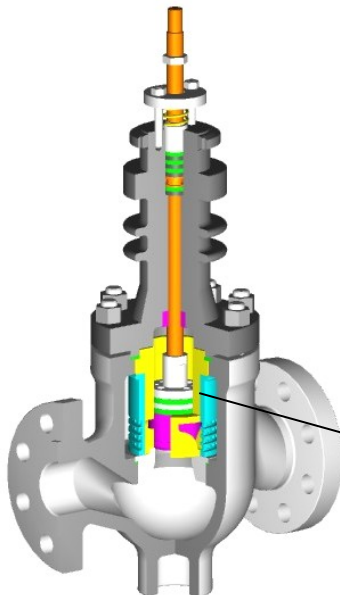
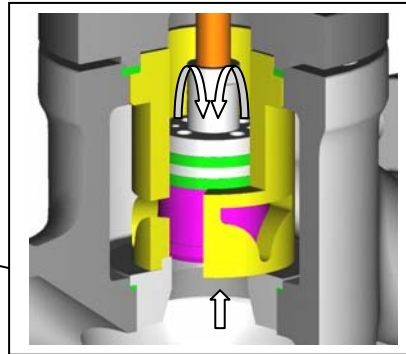

TRIM 2EL

**EQUIPERCENTAGE DOUBLE CAGE**  
from DN 40 to DN 100 **BALANCED** ( DN 25 not balanced )

GABBIA DOPPIA EQUIPERCENTUALE  
dal DN 40 al DN 100 **EQUILIBRATA** ( DN 25 non equilibrata )

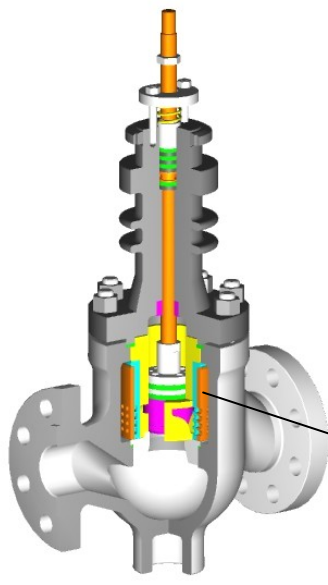
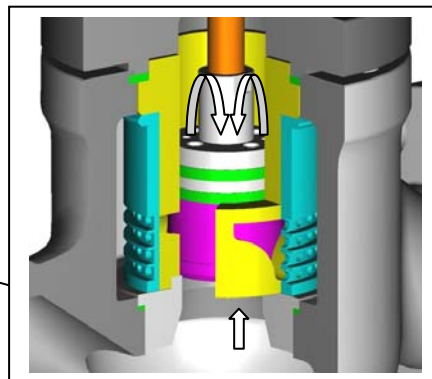

TRIM 3EL

**EQUIPERCENTAGE TRIPLE CAGE**  
from DN 40 to DN 100 **BALANCED** ( DN 25 not balanced )

TRIPLICE GABBIA EQUIPERCENTUALE  
dal DN 40 al DN 100 **EQUILIBRATA** ( DN 25 non equilibrata )

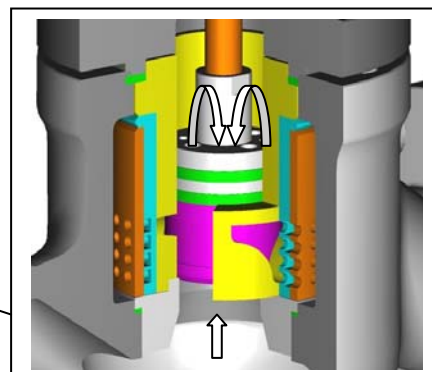



# HP 60 Series

CONFIGURATION BODY GROUP  
Cavitation's Solution

CONFIGURAZIONE GRUPPO CORPO  
Soluzione anti-cavitazione

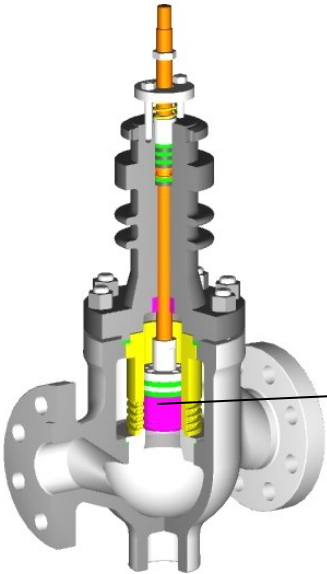
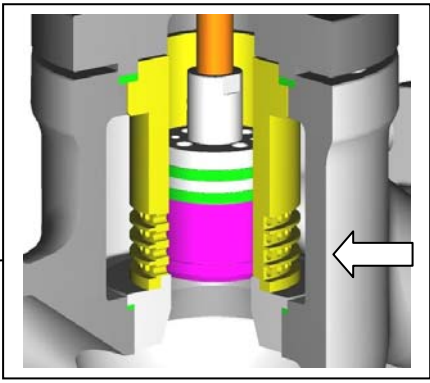
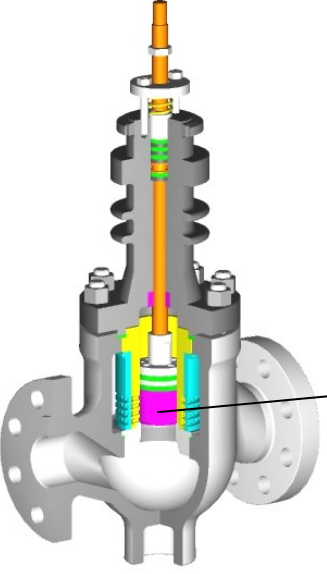
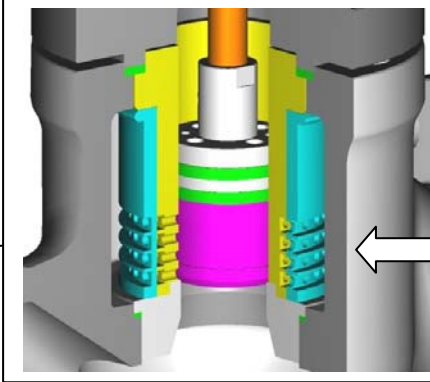
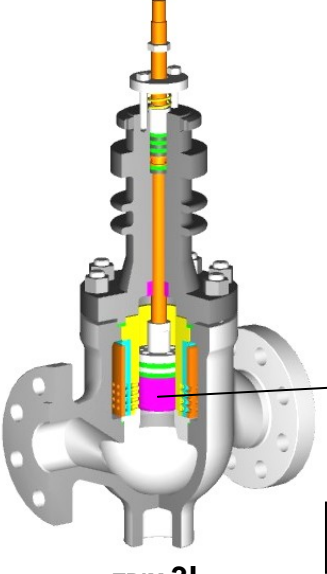
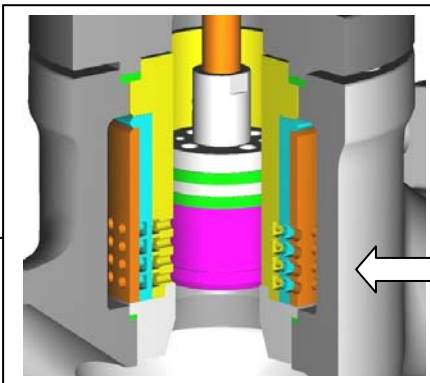
 <p><b>TRIM 1L</b></p>	<p><b>LINEAR SIMPLE CAGE NOT BALANCED</b> GABBIA SEMPLICE LINEARE NON EQUILIBRATA</p> 
 <p><b>TRIM 2L</b></p>	<p><b>LINEAR DOUBLE CAGE NOT BALANCED</b> GABBIA DOPPIA LINEARE NON EQUILIBRATA</p> 
 <p><b>TRIM 3L</b></p>	<p><b>LINEAR TRIPLE CAGE NOT BALANCED</b> TRIPLICE GABBIA LINEARE NON EQUILIBRATA</p> 

# HP 60 Series

CONFIGURATION BODY GROUP  
Contoured Plug

CONFIGURAZIONE GRUPPO CORPO  
Otturatori Profilati

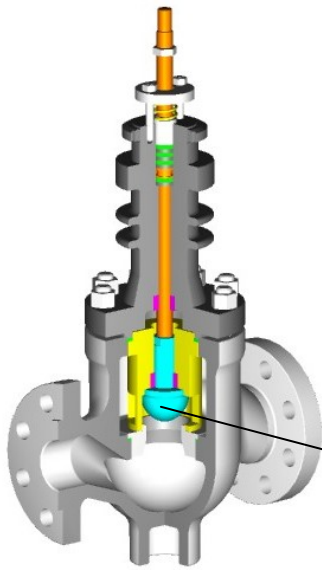

TRIM CPL

**CONTOURED LINEAR PLUG** from DN 25 to DN 50 not balanced

OTTURATORE PROFILATO LINEARE dal DN 25 al DN 50 non bilanciato

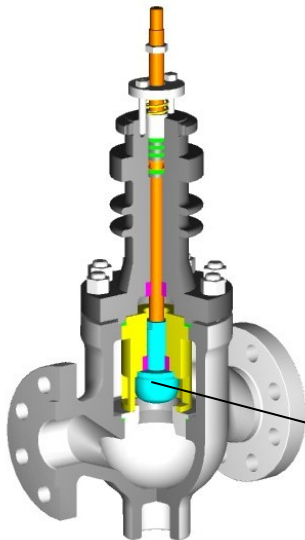
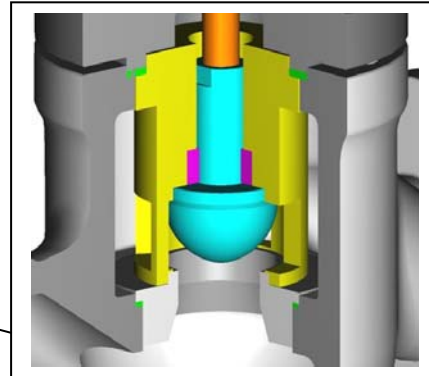

TRIM CPE

**CONTOURED EQUIPERCENTAGE PLUG** from DN 25 to DN 50 not balanced

OTTURATORE PROFILATO EQUIPERCENTUALE dal DN 25 al DN 50 non bilanciato

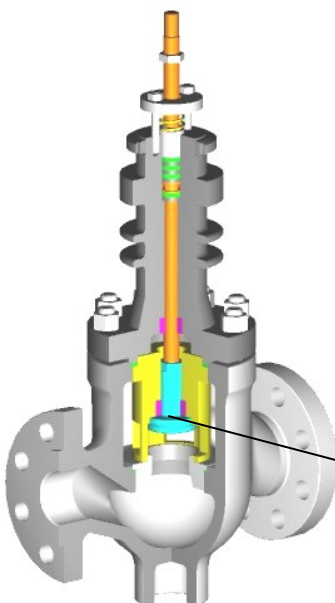
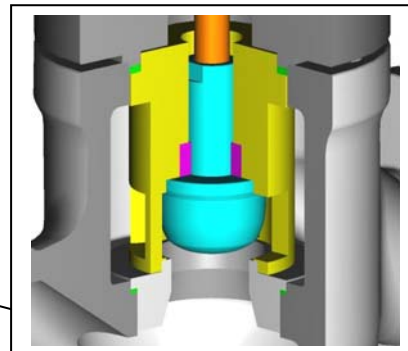

TRIM CPT

**QUICK-OPENING PLUG** from DN 25 to DN 50 not balanced

OTTURATORE APERTURA RAPIDA dal DN 25 al DN 50 non bilanciato

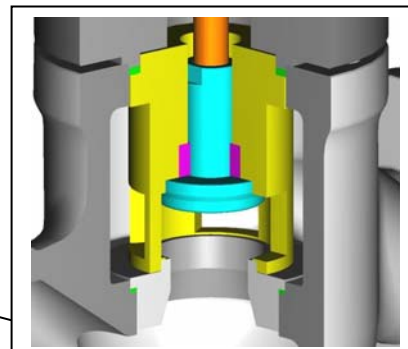

# HP 60 Series

CONFIGURATION BODY GROUP  
Contoured Microflow Plug

CONFIGURAZIONE GRUPPO CORPO  
Otturatori Profilati Microflusso

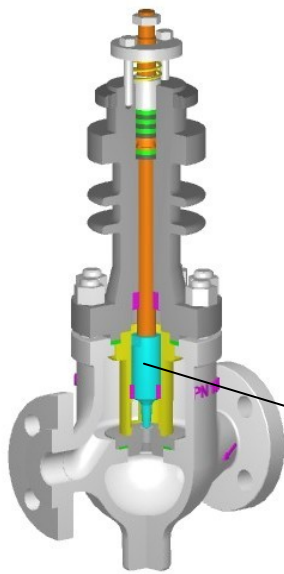

TRIM MFP

**CONTOURED MICROFLOW LINEAR PLUG**  
DN 25 (Ø 1/8" – 3/16" – 1/4" - 3/8") not balanced

OTTURATORE PROFILATO LINEARE MICROFLUSSO  
DN 25 (Ø 1/8" – 3/16" – 1/4" - 3/8") non bilanciato

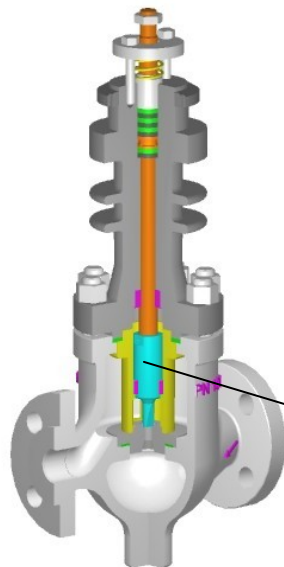
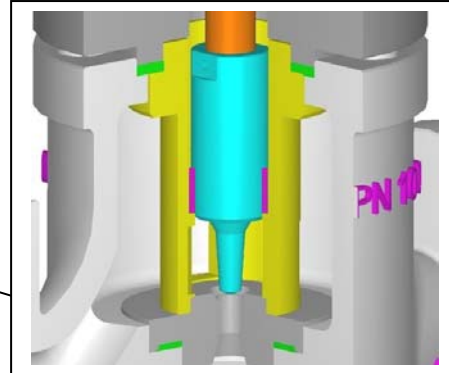

TRIM 1SG

**CONTOURED MICROFLOW EQUIPERCENTAGE PLUG**  
DN 25 (Ø 1/4" – 3/8") not balanced

OTTURATORE PROFILATO EQUIPERCENTUALE MICROFLUSSO  
DN 25 (Ø 1/4" – 3/8") non bilanciato

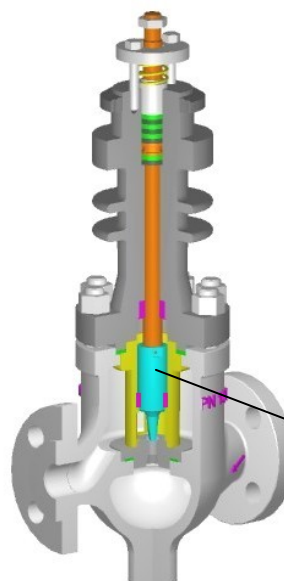
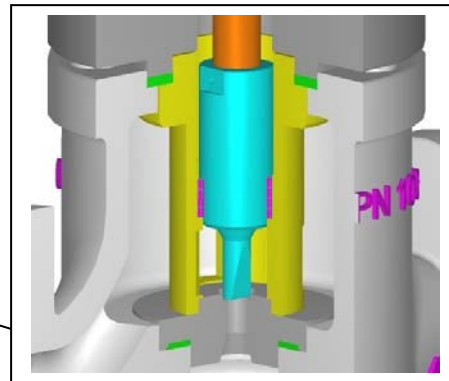

TRIM 2SG

**CONTOURED MICROFLOW EQUIPERCENTAGE PLUG**  
DN 25 (Ø 1/4" – 3/8") not balanced

OTTURATORE PROFILATO EQUIPERCENTUALE MICROFLUSSO  
DN 25 (Ø 1/4" – 3/8") non bilanciato

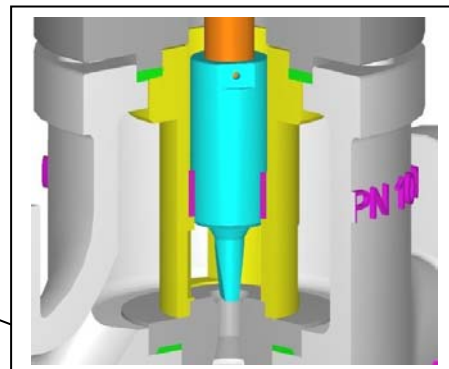

# HP 60 Series

CONFIGURATION BODY GROUP  
Seal insert for leakage class VI

CONFIGURAZIONE GRUPPO CORPO  
Inserto tenuta soffice classe VI

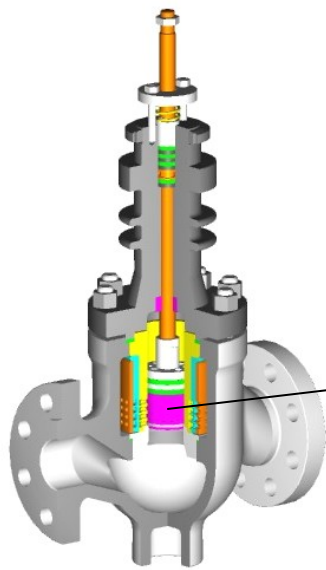

TRIM 1L-2L-3L-1E-2EL-3EL

PTFE or PTFE/GR soft seal DN 25 - 100

TENUTA SOFFICE PTFE o PTFE/GR DN 25 - 100

DETTAGLIO TENUTA SOFFICE

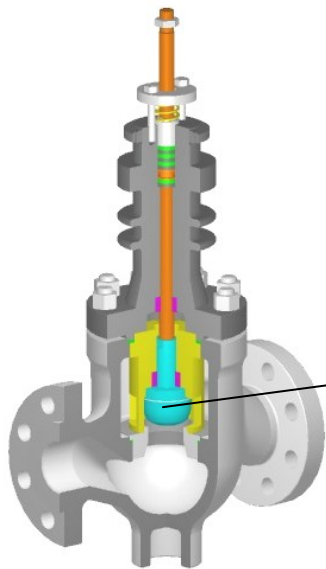
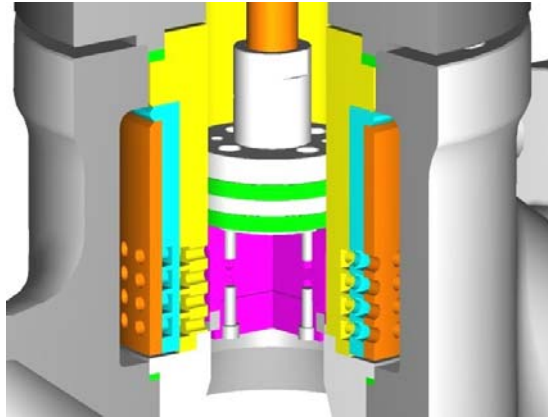

TRIM CPL-CPE-CPT

PTFE or PTFE/GR soft seal DN 25 - 50

TENUTA SOFFICE PTFE o PTFE/GR DN 25 - 50

DETTAGLIO TENUTA SOFFICE

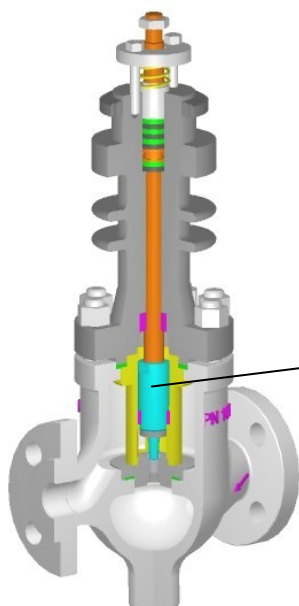
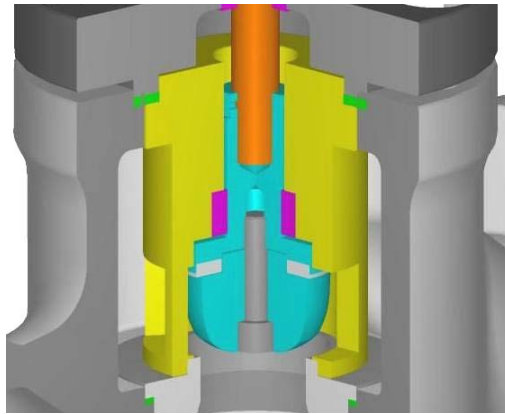

TRIM MFP-1SG-2SG

PTFE or PTFE/GR soft seal DN 25

TENUTA SOFFICE PTFE o PTFE/GR DN 25

DETTAGLIO TENUTA SOFFICE

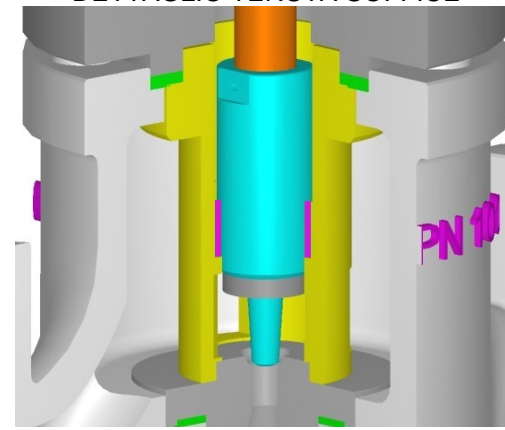

# HP 60 Series

CONFIGURATION  
DIAPHRAGM PNEUMATIC ACTUATOR

CONFIGURAZIONE  
ATTUATORE PNEUMATICO A DIAFRAMMA

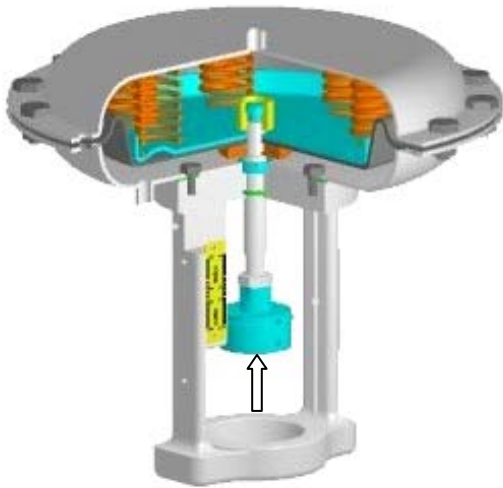

**Type – Tipo RA**

**REVERSE ACTING Normally Closed - Air Opens**  
AZIONE ROVESCIA Normalmente Chiuso - Aria Apre

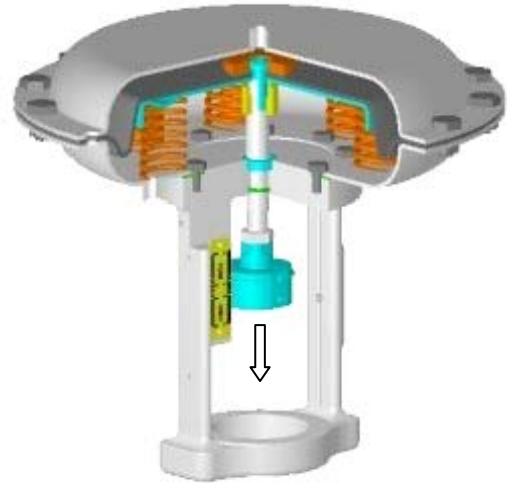

**Type – Tipo DA**

**DIRECT ACTING Normally Open - Air Closes**  
AZIONE DIRETTA Normalmente Aperto - Aria Chiude

*ACCESSORIES*

**Top Manual handwheel**  
**Pneumatic Analogic Positioner**  
**Electropneumatic Smart Positioner**  
**Air Filter Regulator**  
**Lock-up**  
**Solenoid valve**  
**Mechanical switches**  
**Proximity switches**  
**Air Flow Regulator**

*ACCESSORI*

Volantino manuale di testa  
Posizionatore analogico pneumatico  
Posizionatore smart elettro-pneumatico  
Filtro Riduttore  
Rele' di Blocco  
Valvola solenoide  
Fine corsa meccanici  
Fine corsa di prossimità  
Regolatore di flusso

CONFIGURATION  
ELECTRIC ACTUATOR

CONFIGURAZIONE  
ATTUATORE ELETTRICO

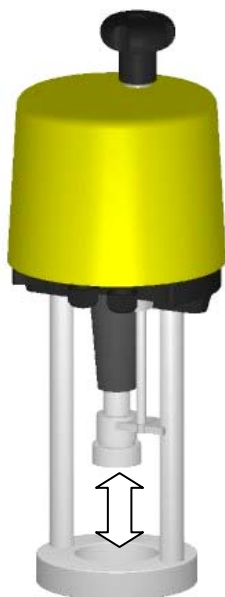

**Tension Opens and Closes**

*ACCESSORIES Type EP*

**Potentiometer**  
**Double Potentiometer**  
**Card Positioner**  
**Feedback card**  
**Mechanical switches**  
**Heating resistor**

**On request :**

**Smart Actuator AMS series**

**ATEX Actuator**  
For gas II2(1)G Ex de [ia] IIC T6/T5  
For dust  
II2(1)D Ex tD [iaD] A21 IP66 T80°C

**Tensione Apre e Chiude**

*ACCESSORI Tipo EP*

**Potenziometro**  
**Doppio Potenziometro**  
**Scheda Posizionatore**  
**Scheda Ritrasmissione**  
**Fine Corsa meccanici**  
**Resistenza di riscaldamento**

**A richiesta :**

**Attuatore Smart Serie AMS**

**Attuatore ATEX**  
Per gas II2(1)G Ex de [ia] IIC T6/T5  
Per Polveri  
II2(1)D Ex tD [iaD] A21 IP66 T80°C

# HP 60 Series

CV coefficients ( max 100 % )

Coefficiente CV ( max 100 % )

VALVE SIZE		PORT	SEAT	TRAVEL	CV max 100 %														
DIAM. VALVOLA		PASS.	SEDE	CORSA	CV max 100 %														
EN	ANSI (inch)	Ø	Ø mm	mm	TYPE OF TRIM – TIPOLOGIA DEL TRIM														
DN	Ø				1L-2L-3L	1E-2EL-3EL	MFP	1SG	2SG	CPL	CPE	CPT							
25	1"	1/8"	3,3	19	n.a.	n.a.	0,25	n.a.		n.a.									
		3/16"	5					0,57											
		1/4"	6,5						0,97				0,24	0,46					
		3/8"	9,5					2,07							0,47	0,87			
		1/2"	16						n.a.				5,86	5,86			5,91		
		3/4"	21						n.a.				9,81	9,81			10,18		
		1"	26					n.a.					15,03	15,03	15,61				
					8,43	7,43													

VALVE SIZE		PORT	SEAT	TRAVEL	CV max 100 %								
DIAM. VALVOLA		PASS.	SEDE	CORSA	CV max 100 %								
EN	ANSI (inch)	Ø	Ø mm	mm	TYPE OF TRIM – TIPOLOGIA DEL TRIM								
DN	Ø				1L	2L	3L	1E	2EL	3EL	CPL	CPE	CPT
40	1.1/2"	1/2"	16	19	n.a.			n.a.			5,86	5,86	5,91
		3/4"	20		n.a.			n.a.			9,81	9,81	10,18
		1"	26		8,43			7,43			15,03	15,03	15,61
		1.1/2"	39	28	22,80			17,33			33,00	29,90	35,10

50	2"	3/4"	20	19	n.a.			n.a.			9,81	9,81	10,18
		1"	26		8,43			7,43			15,03	15,03	15,61
		1.1/2"	39	28	22,88			17,33			33,04	29,93	35,12
		2"	49		36,49			28,51			53,53	47,96	55,45

65	2.1/2"	1"	26	19	8,43			7,43			15,03	15,03	15,61
		1.1/2"	39	28	22,88			17,33			33,04	29,93	35,12
		2"	49		36,49			28,51			53,53	47,96	55,45
		2.1/2"	64	50	65,64			61,92			n.a.		

80	3"	1"	26	19	8,43			7,43			15,03	15,03	15,61
		1.1/2"	39	28	22,88			17,33			33,04	29,93	35,12
		2"	49		36,49			28,51			53,53	47,96	55,45
		2.1/2"	64	50	65,64			61,92			n.a.		
		3"	79		98,7			88,73			n.a.		

100	4"	1"	26	19	8,43			7,43			15,03	15,03	15,61
		1.1/2"	39	28	22,88			17,33			33,04	29,93	35,12
		2"	49		36,49			28,51			53,53	47,96	55,45
		2.1/2"	64	50	65,64			61,92			n.a.		
		3"	79		98,7			88,73			n.a.		
		4"	99		127,71			114,92			n.a.		

n.a. = not applicable / non applicabile

$$KV = CV \times 0.853$$

Reduced special bore on request / Passaggi ridotti speciali a richiesta

# HP 60 Series

CV coefficients ( minimum )

Coefficiente CV ( minimo )

VALVE SIZE		PORT	TRIM TYPE TIPO di TRIM	Minimum Signal - Minimo Segnale		
DIAM. VALVOLA		PASS.		PNEUMATIC VERSION VERSIONE PNEUMATICA		ELECTRIC VERSION
EN	ANSI (inch)	Ø		TYPE of POSITIONER TIPO di POSIZIONATORE		
				SS2	PPL	VERSIONE ELETTRICA
			4,2 Ma	3,5 psi	5,8 mA	

25	1"	1/8"	MFP	0,016	0,017	0,026
		3/16"	MFP	0,027	0,036	0,068
		1/4"	MFP	0,036	0,045	0,086
			1SG - 2SG	0,030 (1)	0,030	0,039
		3/8"	MFP	0,057	0,074	0,16
			1SG - 2SG	0,044 (1)	0,044	0,056
		1/2"	CPL	0,26	0,32	0,64
			CPE	0,23	0,24	0,31
		3/4"	CPL	0,34	0,41	0,81
			CPE	0,29	0,30	0,38
		1"	CPL	0,39	0,42	0,74
			CPE	0,37	0,39	0,47
1L / 2L / 3L	0,53		0,59	0,64		
		1E / 2EL / 3EL	0,02	0,03	0,14	

40	1.1/2"	1/2"	CPL	0,26	0,32	0,64
			CPE	0,23	0,24	0,31
		3/4"	CPL	0,34	0,41	0,81
			CPE	0,29	0,30	0,38
		1"	CPL	0,39	0,42	0,74
			CPE	0,37	0,39	0,47
			1L / 2L / 3L	0,53	0,59	0,64
			1E / 2EL / 3EL	0,02	0,03	0,14
		1.1/2"	CPL	0,6	0,69	1,02
			CPE	0,58	0,63	0,9
			1L / 2L / 3L	0,58	0,65	0,7
			1E / 2EL / 3EL	0,03	0,1	0,18

50	2"	3/4"	CPL	0,34	0,41	0,81
			CPE	0,29	0,30	0,38
		1"	CPL	0,39	0,42	0,74
			CPE	0,37	0,39	0,47
			1L / 2L / 3L	0,53	0,59	0,64
			1E / 2EL / 3EL	0,02	0,03	0,14
		1.1/2"	CPL	0,6	0,69	1,02
			CPE	0,58	0,63	0,9
			1L / 2L / 3L	0,58	0,65	0,7
			1E / 2EL / 3EL	0,03	0,1	0,18
		2"	CPL	0,73	0,82	1,22
			CPE	0,73	0,82	1,19
1L / 2L / 3L	0,62		0,69	0,71		
1E / 2EL / 3EL	0,04		0,12	0,2		

$$KV = CV \times 0.853$$

(1) Minimum CV at 4,2 / 4,5 mA - Minimo CV a 4,2 / 4,5 mA

# HP 60 Series *CV coefficients ( minimum ) - Coefficiente CV ( minimo )*

VALVE SIZE		PORT	TRIM TYPE TIPO di TRIM	Minimum Signal - Minimo Segnal				
DIAM. VALV.		PASS.		PNEUMATIC VERSION VERSIONE PNEUMATICA		ELECTRIC VERSION		
EN	ANSI (inch)	Ø		TYPE of POSITIONER TIPO di POSIZIONATORE		VERSIONE ELETTRICA		
				SS2	PPL			
			4,2 Ma	3,5 psi				
					5,8 mA			
65	2.1/2"	1"	CPL	0,39	0,42	0,74		
			CPE	0,37	0,39	0,47		
			1L / 2L / 3L	0,53	0,59	0,64		
			1E / 2EL / 3EL	0,02	0,03	0,14		
		1.1/2"	CPL	0,6	0,69	1,02		
			CPE	0,58	0,63	0,9		
			1L / 2L / 3L	0,58	0,65	0,7		
			1E / 2EL / 3EL	0,03	0,1	0,18		
		2"	CPL	0,73	0,82	1,22		
			CPE	0,73	0,82	1,19		
			1L / 2L / 3L	0,62	0,69	0,71		
			1E / 2EL / 3EL	0,04	0,12	0,2		
		2.1/2"	1L / 2L / 3L	1,4	2,0	2,33		
			1E / 2EL / 3EL	0,44	0,48	0,68		
		80	3"	1"	CPL	0,39	0,42	0,74
					CPE	0,37	0,39	0,47
1L / 2L / 3L	0,53				0,59	0,64		
1E / 2EL / 3EL	0,02				0,03	0,14		
1.1/2"	CPL			0,6	0,69	1,02		
	CPE			0,58	0,63	0,9		
	1L / 2L / 3L			0,58	0,65	0,7		
	1E / 2EL / 3EL			0,03	0,1	0,18		
2"	CPL			0,73	0,82	1,22		
	CPE			0,73	0,82	1,19		
	1L / 2L / 3L			0,62	0,69	0,71		
	1E / 2EL / 3EL			0,04	0,12	0,2		
2.1/2"	1L / 2L / 3L			1,4	2,0	2,33		
	1E / 2EL / 3EL			0,44	0,48	0,68		
3"	1L / 2L / 3L			2,0	2,7	3,0		
	1E / 2EL / 3EL			0,54	0,59	0,83		
100	4"	1"	CPL	0,39	0,42	0,74		
			CPE	0,37	0,39	0,47		
			1L / 2L / 3L	0,53	0,59	0,64		
			1E / 2EL / 3EL	0,02	0,03	0,14		
		1.1/2"	CPL	0,6	0,69	1,02		
			CPE	0,58	0,63	0,9		
			1L / 2L / 3L	0,58	0,65	0,7		
			1E / 2EL / 3EL	0,03	0,1	0,18		
		2"	CPL	0,73	0,82	1,22		
			CPE	0,73	0,82	1,19		
			1L / 2L / 3L	0,62	0,69	0,71		
			1E / 2EL / 3EL	0,04	0,12	0,2		
		2.1/2"	1L / 2L / 3L	1,4	2,0	2,33		
			1E / 2EL / 3EL	0,44	0,48	0,68		
		3"	1L / 2L / 3L	2,0	2,7	3,0		
			1E / 2EL / 3EL	0,54	0,59	0,83		
4"	1L / 2L / 3L	2,1	2,85	3,1				
	1E / 2EL / 3EL	0,67	0,72	0,96				

**KV = CV x 0.853**



# HP 60 Series

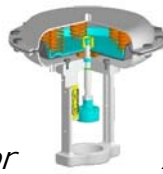

Pressure Drop Table  
Pneumatic Diaphragm Actuator

Tabella Pressioni differenziali  
Attuatori Pneumatici a Diaframma

DN	PORT PASS.	TRAVEL CORSA	TRIM TRIM	ACTUATOR ATTUATORE	SUPPLY 35 PSI			
					ALIMENTAZIONE 35 PSI			
					RA – air to open RA – aria apre		DA – air to close DA – aria chiude	
					6-18 psi	6-30 psi	6-30 psi	
$\Delta P$ shut-off bar								
25	1/8"	19	MFP	T250	960	1536	2687	
	3/16"			T310	418	669	1171	
	1/4"		MFP 1SG - 2SG	T250	247	396	693	
	3/8"			T310	116	185	324	
	1/2"		CPL-CPE-CPT	T250	46	74	130	
				T310	76	121	212	
	3/4"			T250	26	42	73	
				T310	43	77	119	
	1"		CPL-CPE-CPT 1L -2L-3L	T400	63	113	176	
				T250	15	25	43	
			1E-2EL-3EL	T310	25	45	71	
				T400	37	67	104	
	40		1/2"	CPL-CPE-CPT	T500	62	112	174
					T250	26	42	73
T310		43			77	119		
T400		63	113		176			
3/4"		T250	26		42	73		
		T310	43		77	119		
		T400	63	113	176			
1"		CPL-CPE-CPT 1L -2L-3L 1E-2EL-3EL	T250	15	25	43		
			T310	25	45	71		
		1E-2EL-3EL	T400	37	67	104		
			T500	62	112	174		
1.1/2"		28	CPL-CPE-CPT	T310	11	20	31	
				T400	17	30	46	
				T500	28	50	55	
	1L -2L-3L 1E-2EL-3EL		T310	51	92	144		
			T400	76	136	211		
			T500	126	227	252		

# HP 60 Series

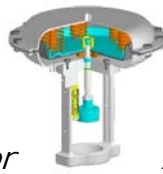

Pressure Drop Table

Pneumatic Diaphragm Actuator

Tabella Pressioni differenziali

Attuatori Pneumatici a Diaframma

DN	PORT PASS.	TRAVEL CORSA	TRIM TRIM	ACTUATOR ATTUATORE	SUPPLY 35 PSI			
					ALIMENTAZIONE 35 PSI			
					RA – air to open RA – aria apre		DA – air to close DA – aria chiude	
					6-18 psi	6-30 psi	6-30 psi	
$\Delta P$ shut-off bar								
50	3/4"	19	CPL-CPE-CPT	T250	26	42	73	
				T310	43	77	119	
				T400	63	113	176	
	1"		CPL-CPE-CPT 1L -2L-3L 1E-2EL-3EL	T250	15	25	43	
				T310	25	45	71	
				T400	37	67	104	
	T500	62		112	174			
	1.1/2"	28		CPL-CPE-CPT	T310	11	20	31
					T400	17	30	46
			T500		28	50	55	
			1L -2L-3L 1E-2EL-3EL	T310	51	92	144	
				T400	76	136	211	
				T500	126	227	252	
	2"	28	CPL-CPE-CPT	T310	7	13	20	
				T400	10	19	29	
				T500	17	31	35	
			1L -2L-3L 1E-2EL-3EL	T310	42	76	93	
				T400	62	111	138	
				T500	103	186	195	

# HP 60 Series

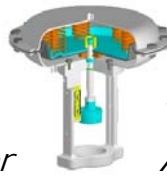

Pressure Drop Table  
Pneumatic Diaphragm Actuator

Tabella Pressioni differenziali  
Attuatori Pneumatici a Diaframma

DN	PORT PASS.	TRAVEL CORSA	TRIM TRIM	ACTUATOR ATTUATORE	SUPPLY 35 PSI		
					ALIMENTAZIONE 35 PSI		
					RA – air to open RA – aria apre		DA – air to close DA – aria chiude
					6-18 psi	6-30 psi	6-30 psi
					$\Delta P$ shut-off bar		
65	1"	19	CPL-CPE-CPT 1L-2L-3L 1EL-2EL-3EL	T250	15	25	43
				T310	25	45	71
				T400	37	67	104
				T500	62	112	174
	1.1/2"	28	CPL-CPE-CPT	T310	11	20	31
				T400	17	30	46
				T500	28	50	55
			1L -2L-3L 1E-2EL-3EL	T310	51	92	144
				T400	76	136	211
				T500	126	227	252
	2"	28	CPL-CPE-CPT	T310	7	13	20
				T400	10	19	29
				T500	17	31	35
			1L -2L-3L 1E-2EL-3EL	T310	42	76	93
				T400	62	111	138
				T500	103	186	195
2.1/2"	50	1L -2L-3L 1E-2EL-3EL	T400	59	95	126	
			T500	99	160	183	
80	1"	19	CPL-CPE-CPT 1L-2L-3L 1EL-2EL-3EL	T250	15	25	43
				T310	25	45	71
				T400	37	67	104
				T500	62	112	174
	1.1/2"	28	CPL-CPE-CPT	T310	11	20	31
				T400	17	30	46
				T500	28	50	55
			1L -2L-3L 1E-2EL-3EL	T310	51	92	144
				T400	76	136	211
				T500	126	227	252
	2"	28	CPL-CPE-CPT	T310	7	13	20
				T400	10	19	29
				T500	17	31	35
			1L -2L-3L 1E-2EL-3EL	T310	42	76	93
				T400	62	111	138
				T500	103	186	195
2.1/2"	50	1L -2L-3L	T400	59	95	126	
			T500	99	160	183	
3"	50	1E-2EL-3EL	T400	55	88	114	
			T500	91	147	167	

# HP 60 Series

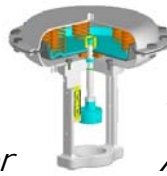

Pressure Drop Table  
Pneumatic Diaphragm Actuator

Tabella Pressioni differenziali  
Attuatori Pneumatici a Diaframma

DN	PORT PASS.	TRAVEL CORSA	TRIM TRIM	ACTUATOR ATTUATORE	SUPPLY 35 PSI		
					ALIMENTAZIONE 35 PSI		
					RA – air to open RA – aria apre		DA – air to close DA – aria chiude
					6-18 psi	6-30 psi	6-30 psi
					$\Delta P$ shut-off bar		
100	1"	19	CPL-CPE-CPT 1L-2L-3L 1EL-2EL-3EL	T250	15	25	43
				T310	25	45	71
				T400	37	67	104
				T500	62	112	174
	1.1/2"	28	CPL-CPE-CPT	T310	11	20	31
				T400	17	30	46
				T500	28	50	55
			1L -2L-3L 1E-2EL-3EL	T310	51	92	144
				T400	76	136	211
				T500	126	227	252
	2"	28	CPL-CPE-CPT	T310	7	13	20
				T400	10	19	29
				T500	17	31	35
			1L -2L-3L 1E-2EL-3EL	T310	42	76	93
				T400	62	111	138
				T500	103	186	195
	2.1/2"	50	1L -2L-3L 1E-2EL-3EL	T400	59	95	126
	T500			99	160	183	
	3"			T400	55	88	114
	T500			91	147	167	
4"	T400			50	81	98	
	T500			84	135	145	

# HP 60 Series

Pressure Drop Table  
Electric Actuator



Tabella Pressioni differenziali  
Attuatori Elettrici

DN	PORT PASS.	TRAVEL CORSA	TRIM TRIM	ACTUATOR ATTUATORE	SUPPLY 24 V AC / DC – 110 V AC – 230 V AC – 400 V3			
					EP – Tension opens & closes EP – Tensione apre & chiude			
					$\Delta P$ shut-off bar	Speed / Velocità travel/s – corsa/s		
25	1/8"	19	MFP	PSL 201	1074	64		
	3/16"				468			
	1/4"		277					
	3/8"		130					
	1/2"		CPL-CPE-CPT	PSL 201	52	64		
				PSL 202	104	32		
	3/4"			PSL 201	29	64		
				PSL 202	58	32		
				PSL 204	132			
				1"	CPL-CPE-CPT 1L -2L-3L 1E-2EL-3EL	PSL 201	17	64
	PSL 202		35			32		
	PSL 204		78					
	PSL 210		173					
	40		1/2"	19	CPL-CPE-CPT		PSL 201	52
PSL 202		104				32		
3/4"		PSL 201	29			64		
		PSL 202	58			32		
1"		PSL 204	132				32	
		PSL 201	17			64		
		PSL 202	35			32		
		PSL 204	78					
PSL 210		173						
1.1/2"		28	PSL 201				8	94
			PSL 202			15	47	
			PSL 204			35		
			PSL 210			77		
			PSL 214			108		52
			1L -2L-3L 1E-2EL-3EL			PSL 201	39	94
						PSL 202	78	47
	PSL 204			156				

# HP 60 Series

Pressure Drop Table  
Electric Actuator



Tabella Pressioni differenziali  
Attuatori Elettrici

DN	PORT PASS.	TRAVEL CORSA	TRIM TRIM	ACTUATOR ATTUATORE	SUPPLY 24 V AC / DC – 110 V AC – 230 V AC – 400 V3	
					EP – Tension opens & closes EP – Tensione apre & chiude	
					$\Delta P$ shut-off bar	Speed / Velocità travel/s – corsa/s
50	3/4"	19	CPL-CPE-CPT	PSL 201	29	64
				PSL 202	58	32
				PSL 204	132	
	PSL 201			17	64	
	PSL 202			35	32	
	PSL 204			78		
	PSL 210	173				
	1"	28		PSL 201	8	94
				PSL 202	15	47
				PSL 204	35	
	PSL 210			77		
	PSL 214			108	52	
	PSL 201			5	94	
	1.1/2"	28		PSL 202	10	47
				PSL 204	22	
				PSL 210	49	
				PSL 214	68	52
				PSL 320	103	24
			PSL 201	32	94	
	2"	28	1L -2L-3L	PSL 201	32	94
1E-2EL-3EL			PSL 202	64	47	
			PSL 204	128		

# HP 60 Series



Pressure Drop Table  
Electric Actuator

Tabella Pressioni differenziali  
Attuatori Elettrici

DN	PORT PASS.	TRAVEL CORSA	TRIM TRIM	ACTUATOR ATTUATORE	SUPPLY 24 V AC / DC – 110 V AC – 230 V AC – 400 V3	
					EP – Tension opens & closes EP – Tensione apre & chiude	
					$\Delta P$ shut-off bar	Speed / Velocità Travel/s- Corsa/s
65	1"	19		PSL 201	17	64
				PSL 202	35	32
				PSL 204	78	
				PSL 210	173	
	1.1/2"	28	CPL-CPE-CPT	PSL 201	8	94
				PSL 202	15	47
				PSL 204	35	
				PSL 210	77	
			1L -2L-3L 1E-2EL-3EL	PSL 201	39	94
				PSL 202	78	47
				PSL 204	156	
				2"	28	CPL-CPE-CPT
	PSL 202	10	47			
	PSL 204	22				
	1L -2L-3L 1E-2EL-3EL	PSL 210	49			52
		PSL 214	68			
		PSL 320	103			
	2.1/2"	50	1L -2L-3L 1E-2EL-3EL	PSL 201	32	94
				PSL 202	64	47
				PSL 204	128	
	2.1/2"	50	1L -2L-3L 1E-2EL-3EL	PSL 201	31	200
				PSL 202	61	100
				PSL 204	122	

# HP 60 Series



Pressure Drop Table  
Electric Actuator

Tabella Pressioni differenziali  
Attuatori Elettrici

DN	PORT PASS.	TRAVEL CORSA	TRIM TRIM	ACTUATOR ATTUATORE	SUPPLY 24 V AC / DC – 110 V AC – 230 V AC – 400 V3	
					EP – Tension opens & closes EP – Tensione apre & chiude	
					$\Delta P$ shut-off bar	Speed / Velocità Travel/s- Corsa/s
80	1"	28	CPL-CPE-CPT	PSL 201	17	64
				PSL 202	35	32
				PSL 204	78	
				PSL 210	173	
	1.1/2"		CPL-CPE-CPT	PSL 201	8	94
				PSL 202	15	47
				PSL 204	35	
				PSL 210	77	
			1L -2L-3L 1E-2EL-3EL	PSL 214	108	52
				PSL 201	39	94
				PSL 202	78	47
				PSL 204	156	
	2"	CPL-CPE-CPT	PSL 201	5	94	
			PSL 202	10	47	
			PSL 204	22		
			PSL 210	49		
		1L -2L-3L 1E-2EL-3EL	PSL 214	68	52	
			PSL 320	103	24	
			PSL 201	32	94	
			PSL 202	64	47	
	PSL 204	128				
	2.1/2"	50	1L -2L-3L	PSL 201	31	200
				PSL 202	61	100
	PSL 204			122		
3"	1E-2EL-3EL		PSL 201	28	200	
			PSL 202	56	100	
			PSL 204	113		



# HP 60 Series



Pressure Drop Table  
Electric Actuator

Tabella Pressioni differenziali  
Attuatori Elettrici

DN	PORT PASS.	TRAVEL CORSA	TRIM TRIM	ACTUATOR ATTUATORE	SUPPLY 24 V AC / DC – 110 V AC – 230 V AC – 400 V3		
					EP – Tension opens & closes EP – Tensione apre & chiude		
					$\Delta P$ shut-off bar	Speed / Velocità Travel/s- Corsa/s	
100	1"	28	CPL-CPE-CPT	PSL 201	17	64	
				PSL 202	35	32	
				PSL 204	78		
	PSL 210			173			
	PSL 201			8	94		
	PSL 202			15	47		
	PSL 204			35			
	PSL 210			77			
	PSL 214			108	52		
	1.1/2"		1L -2L-3L	PSL 201	39	94	
				PSL 202	78	47	
				PSL 204	156		
			1E-2EL-3EL	PSL 201	5	94	
				PSL 202	10	47	
				PSL 204	22		
	2"		CPL-CPE-CPT	PSL 210	49		
				PSL 214	68	52	
				PSL 320	103	24	
			1L -2L-3L	PSL 201	32	94	
				PSL 202	64	47	
				PSL 204	128		
	2.1/2"		50	1L -2L-3L 1E-2EL-3EL	PSL 201	31	200
					PSL 202	61	100
					PSL 204	122	
3"	PSL 201	28			200		
	PSL 202	56			100		
	PSL 204	113					
4"	PSL 201	26			200		
	PSL 202	52			100		
	PSL 204	104					

On request different types of actuation speed - A richiesta attuatori con differenti velocità di attuazione

TRIM 1L			CARBON STEEL		STAINLESS STEEL
			Acciaio Carbonio		Acciaio Inox
TEMPERATURE RANGE			- 20 / +425 °C	- 45 / +343 °C	- 196 / +425 °C
Range Temperature					
Item	Description	Descrizione			
1	Body	Corpo	A 216 WCB (1)	A 352 LCB (1)	A351 CF8M
2	Seat	Sede	AISI 316 + stellite		
3	Seat Gasket	Guarnizione Sede	Thermiculite 815		
4	Main Linear Cage	Gabbia principale	AISI 316		
5	Piston	Pistone	AISI 316 + stellite		
5b	Inferior piston plate	Fondello inferiore	AISI 316		
5c	Soft seal class VI°	Anello classe VI°	PTFE or PTFE/GR		
5d	Inferior piston plate screws	Viti serr. inferiori	ISO 4762 Cl. A2		
6	Medium piston plate	Fondello intermedio	AISI 316		
7	Seal Rings	Anelli di Tenuta	Graphite + Antimon / Grafite + Antimonio		
8	Superior piston plate	Fondello Superiore	AISI 316		
9	Piston upper screws	Viti Serr. Pistone	ISO 4762 Cl. A2		
10	Body Gasket	Guarnizione Corpo	Spirometal / Spirotallica – AISI 304 + Graphite		
11	Bonnet	Flangia superiore	A 216 WCB (1)	A 352 LCB (1)	A351 CF8M
12	Body Stud Bolts	Prigionieri corpo	A193 B7 galvanized	A193 B7 (2) galvanized	A193 B7 (2) galvanized
13	Body Nuts	Dadi	A194 2H galvanized	A194 2H (2) galvanized	A194 2H (2) galvanized
14	Guide bushing	Bussola guida	AISI 304		
15	Stem	Stelo	AISI 316		
16	Packing	Premistoppa	Pure Graphite – Grafite Pura		
			PTFE (PTFE V rings 100 %) on request TA-LUFT		
			PTFE/GR (PTFE V RINGS 85% + Graphite V rings 15 %)		
17	Snore-piece packing	Lanterna	AISI 316		
18	Packing Guide	Bussola prem.	AISI 316		
19	Packing Spring	Molla prem.	AISI 302		
20	Yoke Lock Nut	Ghiera blocc. Cast.	Carbon steel Cl. 6S galvanized – Acc. Carb. Zincato Cl. 6S		
21	Packing Stud Bolts	Tiranti prem.	A193 B8		
22	Packing flange	Flangia prem.	AISI 304		
23	Packing Lock Nuts	Dadi tiranti prem.	A 194 Gr.8		
24	Stem nut	Dado serr. Stelo	A 194 Gr.8		

- (1) Silicon high temperature painture up to 600 °C 25 µ  
 (2) For temperature < - 20 °C s.s. A193 B8 + A194 Gr.8

Verniciatura siliconica resistente alle alte temperature 600 °C 25 µ  
 Per temperature < - 20 °C Acc. Inox A193 B8 + A194 Gr.8

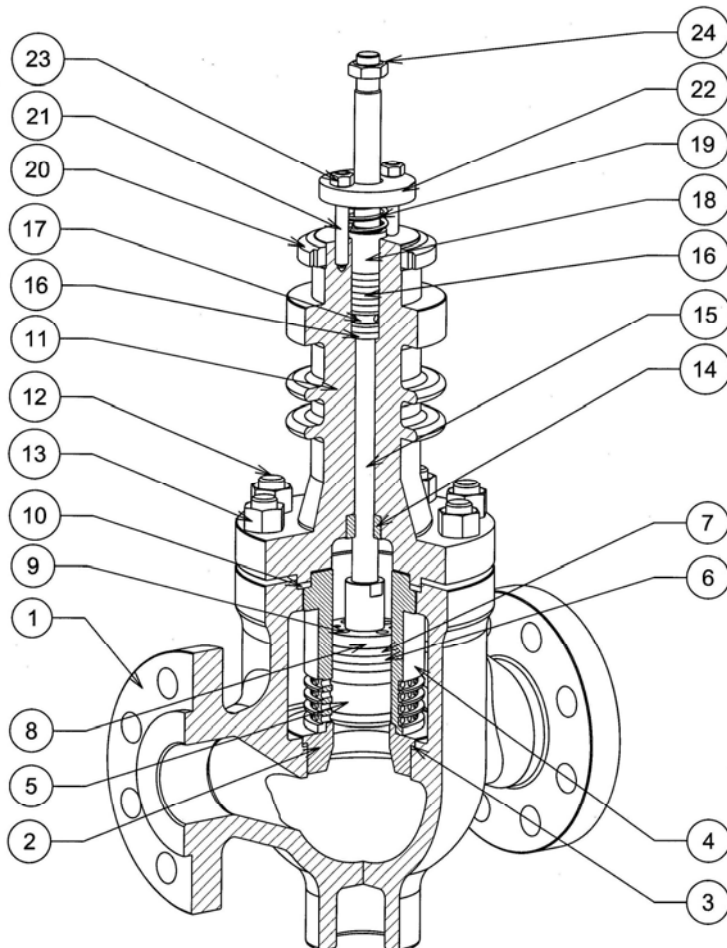

DN 40-100

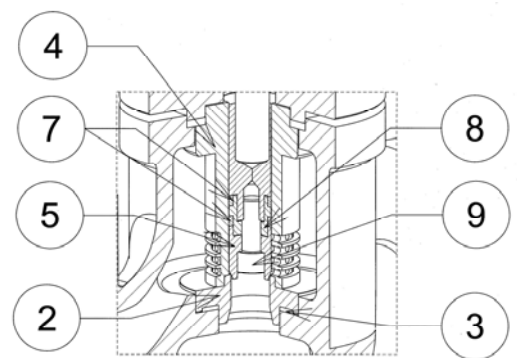

DN 25

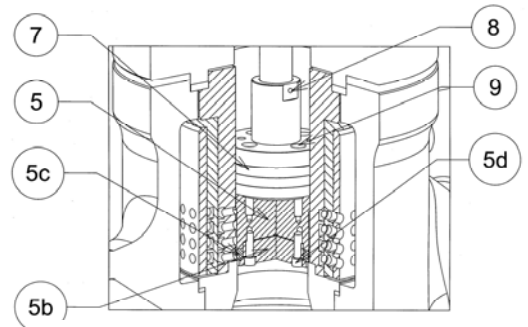

**SOFT SEAL Detail**  
 Dettaglio TENUTA SOFFICE

TRIM 2L			CARBON STEEL		STAINLESS STEEL
			Acciaio Carbonio		Acciaio Inox
TEMPERATURE RANGE			- 20 / +425 °C	- 45 / +343 °C	- 196 / +425 °C
Range Temperature					
Item	Description	Descrizione			
1	Body	Corpo	A 216 WCB (1)	A 352 LCB (1)	A351 CF8M
2	Seat	Sede	AISI 316 + stellite		
3	Seat Gasket	Guarnizione Sede	Thermiculite 815		
4	Main Linear Cage	Gabbia principale	AISI 316		
4a	Second Cage	Seconda Gabbia	AISI 316		
5	Piston	Pistone	AISI 316 + stellite		
6	Medium piston plate	Fondello intermedio	AISI 316		
7	Seal Rings	Anelli di Tenuta	Graphite + Antimonio / Grafite + Antimonio		
8	Superior piston plate	Fondello Superiore	AISI 316		
9	Piston Screws	Viti Serr. Pistone	ISO 4762 Cl. A2		
10	Body Gasket	Guarnizione Corpo	Spirometal / Spirotallica – AISI 304 + Graphite		
11	Bonnet	Flangia superiore	A 216 WCB (1)	A 352 LCB (1)	A351 CF8M
12	Body Stud Bolts	Prigionieri corpo	A193 B7 galvanized	A193 B7 (2) galvanized	A193 B7 (2) galvanized
13	Body Nuts	Dadi	A194 2H galvanized	A194 2H (2) galvanized	A194 2H (2) galvanized
14	Guide bushing	Bussola guida	AISI 304		
15	Stem	Stelo	AISI 316		
16	Packing	Premistoppa	Pure Graphite – Grafite Pura		
			PTFE (PTFE V rings 100 %) <b>TA-LUFT on request</b>		
			PTFE/GR (PTFE V RINGS 85% + Graphite V rings 15 %)		
17	Snore-piece packing	Lanterna	AISI 316		
18	Packing Guide	Bussola prem.	AISI 316		
19	Packing Spring	Molla prem.	AISI 302		
20	Yoke Lock Nut	Ghiera blocc. Cast.	Carbon steel Cl. 6S galvanized – Acc. Carb. Zincato Cl. 6S		
21	Packing Stud Bolts	Tiranti prem.	A193 B8		
22	Packing flange	Flangia prem.	AISI 304		
23	Packing Lock Nuts	Dadi tiranti prem.	A 194 Gr.8		
24	Stem nut	Dado serr. Stelo	A 194 Gr.8		

- (1) Silicon high temperature painture up to 600 °C 25 µ  
 (2) For temperature < - 20 °C s.s. A193 B8 + A194 Gr.8

Verniciatura silconica resistente alle alte temperature 600 °C 25 µ  
 Per temperature < - 20 °C Acc. Inox A193 B8 + A194 Gr.8

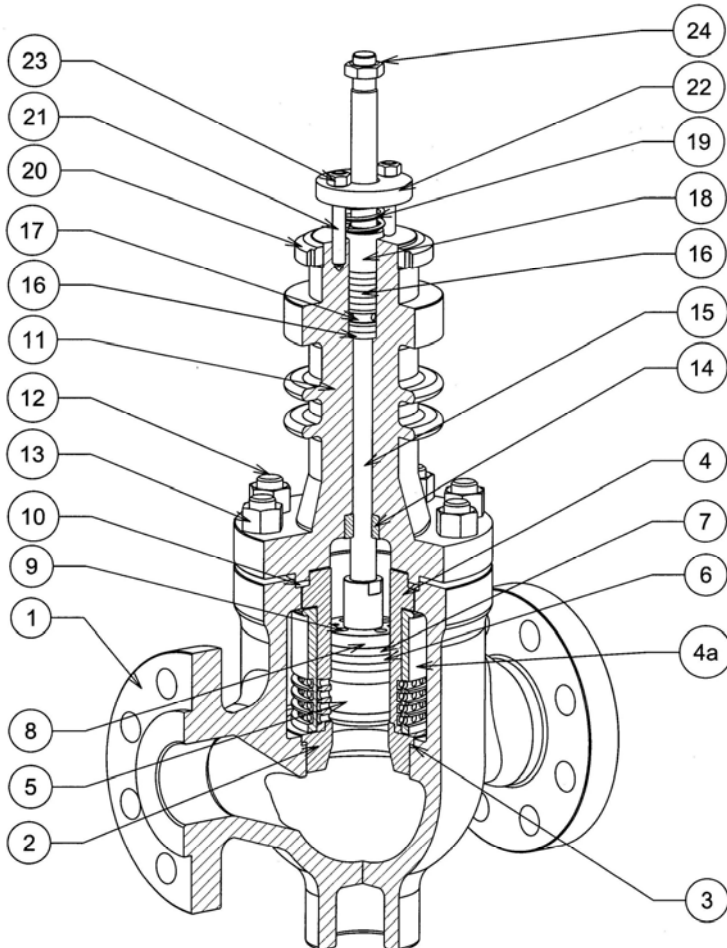

DN 50 - 100

**For soft seal class VI° see TRIM 1L**  
 Per la tenuta soffice classe VI°  
 vedi TRIM 1L

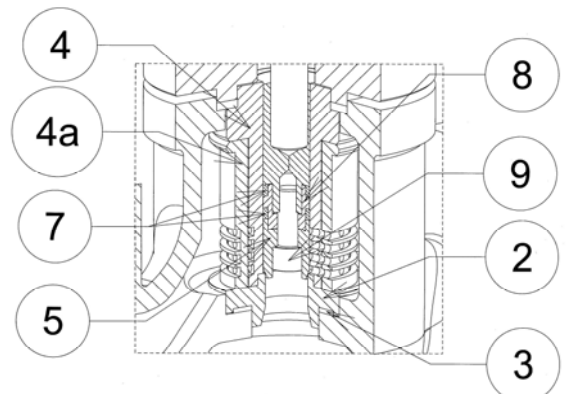

DN 25 - 40

TRIM 3L			CARBON STEEL		STAINLESS STEEL
			Acciaio Carbonio		Acciaio Inox
TEMPERATURE RANGE			- 20 / +425 °C	- 45 / +343 °C	- 196 / +425 °C
Range Temperature					
Item	Description	Descrizione			
1	Body	Corpo	A 216 WCB (1)	A 352 LCB (1)	A351 CF8M
2	Seat	Sede	AISI 316 + stellite		
3	Seat Gasket	Guarnizione Sede	Thermiculite 815		
4	Main Linear Cage	Gabbia principale	AISI 316		
4a	Second Cage	Seconda Gabbia	AISI 316		
4b	Third Cage	Terza Gabbia	AISI 316		
5	Piston	Pistone	AISI 316 + stellite		
6	Medium piston plate	Fondello intermedio	AISI 316		
7	Seal Rings	Anelli di Tenuta	Graphite + Antimon / Grafite + Antimonio		
8	Superior piston plate	Fondello Superiore	AISI 316		
9	Piston Screws	Viti Serr. Pistone	ISO 4762 Cl. A2		
10	Body Gasket	Guarnizione Corpo	Spirometal / Spirotallica – AISI 304 + Graphite		
11	Bonnet	Flangia superiore	A 216 WCB (1)	A 352 LCB (1)	A351 CF8M
12	Body Stud Bolts	Prigionieri corpo	A193 B7 galvanized	A193 B7 (2) galvanized	A193 B7 (2) galvanized
13	Body Nuts	Dadi	A194 2H galvanized	A194 2H (2) galvanized	A194 2H (2) galvanized
14	Guide bushing	Bussola guida	AISI 304		
15	Stem	Stelo	AISI 316		
16	Packing	Premistoppa	Pure Graphite – Grafite Pura		
			PTFE (PTFE V rings 100 % ) <b>TA-LUFT on request</b>		
			PTFE/GR (PTFE V RINGS 85% + Graphite V rings 15 %)		
17	Snore-piece packing	Lanterna	AISI 316		
18	Packing Guide	Bussola prem.	AISI 316		
19	Packing Spring	Molla prem.	AISI 302		
20	Yoke Lock Nut	Ghiera blocc. Cast.	Carbon steel Cl. 6S galvanized – Acc. Carb. Zincato Cl. 6S		
21	Packing Stud Bolts	Tiranti prem.	A193 B8		
22	Packing flange	Flangia prem.	AISI 304		
23	Packing Lock Nuts	Dadi tiranti prem.	A 194 Gr.8		
24	Stem nut	Dado serr. Stelo	A 194 Gr.8		

- (1) Silicon high temperature painture up to 600 °C 25 µ  
 (2) For temperature < - 20 °C s.s. A193 B8 + A194 Gr.8

Verniciatura silconica resistente alle alte temperature 600 °C 25 µ  
 Per temperature < - 20 °C Acc. Inox A193 B8 + A194 Gr.8

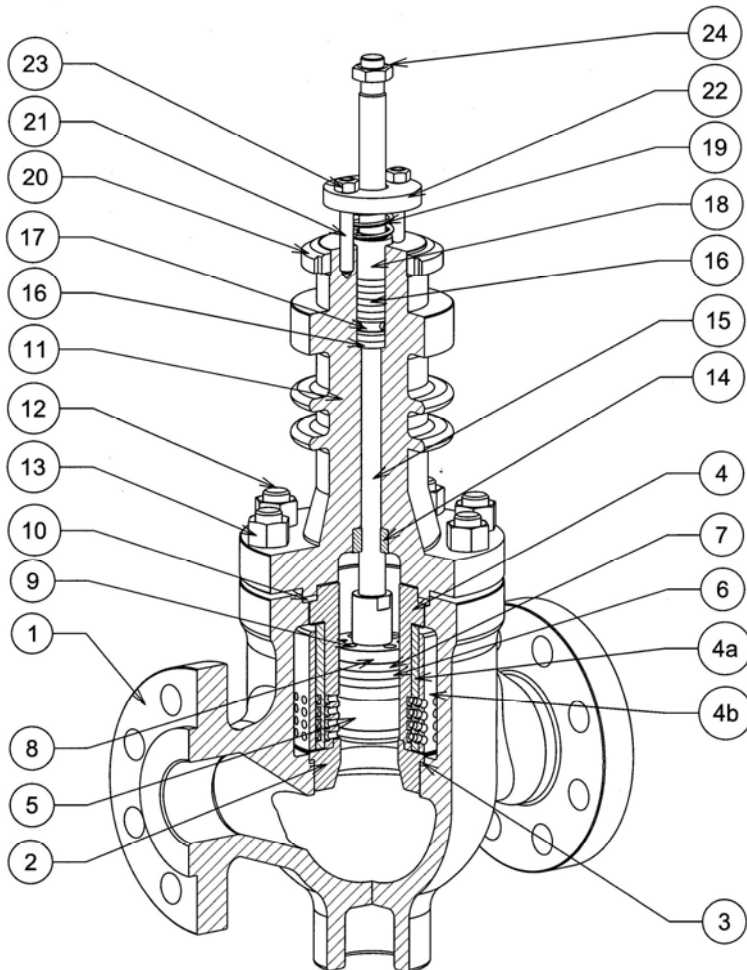

DN 50 - 100

**For soft seal class VI° see TRIM 1L**  
 Per la tenuta soffice classe VI°  
 vedi TRIM 1L

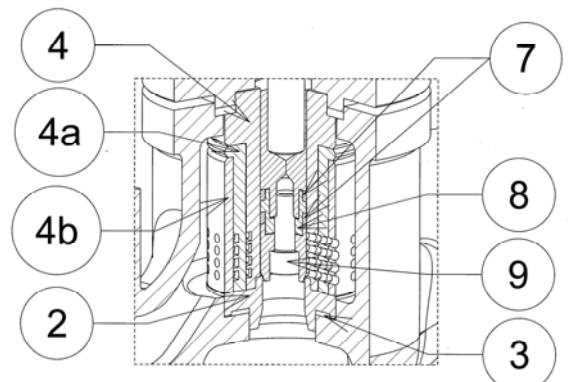

DN 25 - 40

TRIM 1E			CARBON STEEL		STAINLESS STEEL
			Acciaio Carbonio		Acciaio Inox
TEMPERATURE RANGE			- 20 / +425 °C	- 45 / +343 °C	- 196 / +425 °C
Range Temperature					
Item	Description	Descrizione			
1	Body	Corpo	A 216 WCB (1)	A 352 LCB (1)	A351 CF8M
2	Seat	Sede	AISI 316 + stellite		
3	Seat Gasket	Guarnizione Sede	Thermiculite 815		
4	Main Equipercantage Cage	Gabbia principale	AISI 316		
5	Piston	Pistone	AISI 316 + stellite		
5b	Inferior piston plate	Fondello inferiore	AISI 316		
5c	Soft seal class VI°	Anello classe VI°	PTFE or PTFE/GR		
5d	Inferior piston plate screws	Viti serr. inferiori	ISO 4762 Cl. A2		
6	Medium piston plate	Fondello intermedio	AISI 316		
7	Seal Rings	Anelli di Tenuta	Graphite + Antimon / Grafite + Antimonio		
8	Superior piston plate	Fondello Superiore	AISI 316		
9	Piston Screws	Viti Serr. Pistone	ISO 4762 Cl. A2		
10	Body Gasket	Guarnizione Corpo	Spirometal / Spirotallica – AISI 304 + Graphite		
11	Bonnet	Flangia superiore	A 216 WCB (1)	A 352 LCB (1)	A351 CF8M
12	Body Stud Bolts	Prigionieri corpo	A193 B7 galvanized	A193 B7 (2) galvanized	A193 B7 (2) galvanized
13	Body Nuts	Dadi	A194 2H galvanized	A194 2H (2) galvanized	A194 2H (2) galvanized
14	Guide bushing	Bussola guida	AISI 304		
15	Stem	Stelo	AISI 316		
16	Packing	Premistoppa	Pure Graphite – Grafite Pura		
			PTFE (PTFE V rings 100 %) TA-LUFT on request		
			PTFE/GR (PTFE V RINGS 85% + Graphite V rings 15 %)		
17	Snore-piece packing	Lanterna	AISI 316		
18	Packing Guide	Bussola prem.	AISI 316		
19	Packing Spring	Molla prem.	AISI 302		
20	Yoke Lock Nut	Ghiera blocc. Cast.	Carbon steel Cl. 6S galvanized – Acc. Carb. Zincato Cl. 6S		
21	Packing Stud Bolts	Tiranti prem.	A193 B8		
22	Packing flange	Flangia prem.	AISI 304		
23	Packing Lock Nuts	Dadi tiranti prem.	A 194 Gr.8		
24	Stem nut	Dado serr. Stelo	A 194 Gr.8		

- (1) Silicon high temperature painture up to 600 °C 25 µ  
 (2) For temperature < - 20 °C s.s. A193 B8 + A194 Gr.8

Verniciatura silconica resistente alle alte temperature 600 °C 25 µ  
 Per temperature < - 20 °C Acc. Inox A193 B8 + A194 Gr.8

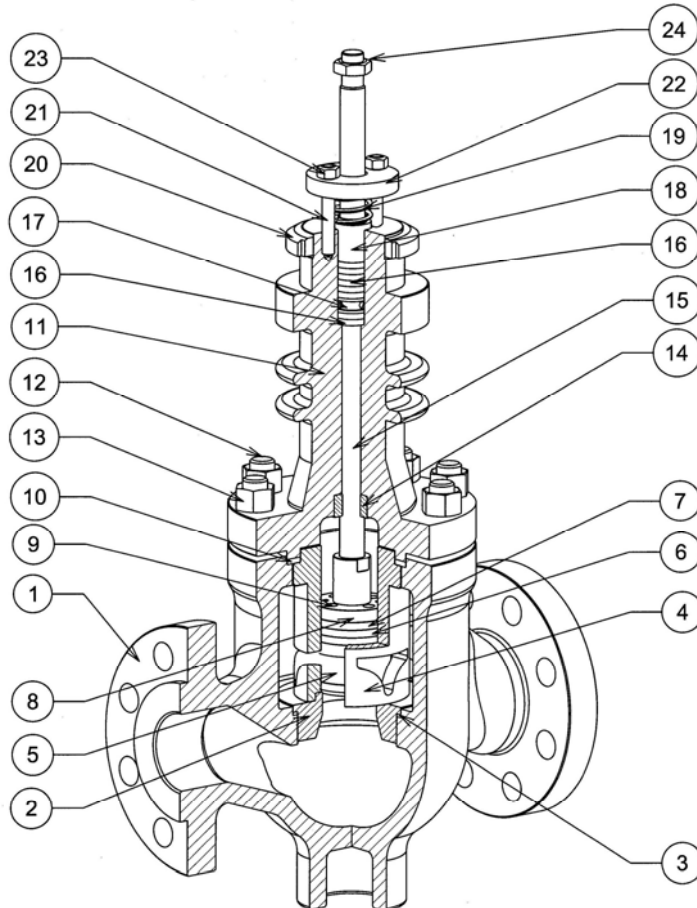

DN 50 - 100

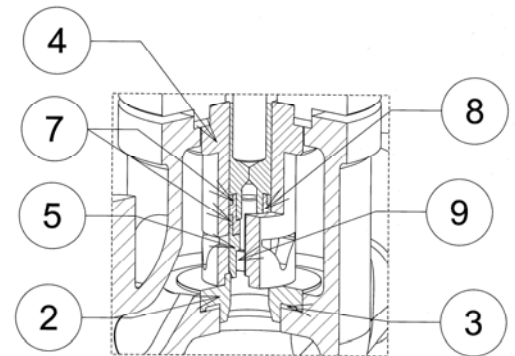

DN 40 - 50

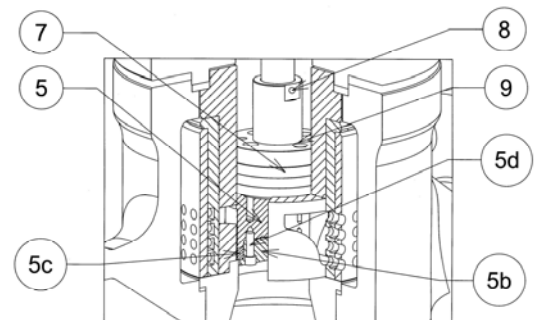

**SOFT SEAL Detail**  
 Dettaglio TENUTA SOFFICE

TRIM 2EL			CARBON STEEL		STAINLESS STEEL
			Acciaio Carbonio		Acciaio Inox
TEMPERATURE RANGE			- 20 / +425 °C	- 45 / +343 °C	- 196 / +425 °C
Range Temperature					
Item	Description	Descrizione			
1	Body	Corpo	A 216 WCB (1)	A 352 LCB (1)	A351 CF8M
2	Seat	Sede	AISI 316 + stellite		
3	Seat Gasket	Guarnizione Sede	Thermiculite 815		
4	Main Euipercentage Cage	Gabbia principale	AISI 316		
4a	Second Cage	Seconda Gabbia	AISI 316		
5	Piston	Pistone	AISI 316 + stellite		
6	Medium piston plate	Fondello intermedio	AISI 316		
7	Seal Rings	Anelli di Tenuta	Graphite + Antimon / Grafite + Antimonio		
8	Superior piston plate	Fondello Superiore	AISI 316		
9	Piston Screws	Viti Serr. Pistone	ISO 4762 Cl. A2		
10	Body Gasket	Guarnizione Corpo	Spirometal / Spirotallica – AISI 304 + Graphite		
11	Bonnet	Flangia superiore	A 216 WCB (1)	A 352 LCB (1)	A351 CF8M
12	Body Stud Bolts	Prigionieri corpo	A193 B7 galvanized	A193 B7 (2) galvanized	A193 B7 (2) galvanized
13	Body Nuts	Dadi	A194 2H galvanized	A194 2H (2) galvanized	A194 2H (2) galvanized
14	Guide bushing	Bussola guida	AISI 304		
15	Stem	Stelo	AISI 316		
16	Packing	Premistoppa	Pure Graphite – Grafite Pura		
			PTFE (PTFE V rings 100 %) TA-LUFT on request		
			PTFE/GR (PTFE V RINGS 85% + Graphite V rings 15 %)		
17	Snore-piece packing	Lanterna	AISI 316		
18	Packing Guide	Bussola prem.	AISI 316		
19	Packing Spring	Molla prem.	AISI 302		
20	Yoke Lock Nut	Ghiera blocc. Cast.	Carbon steel Cl. 6S galvanized – Acc. Carb. Zincato Cl. 6S		
21	Packing Stud Bolts	Tiranti prem.	A193 B8		
22	Packing flange	Flangia prem.	AISI 304		
23	Packing Lock Nuts	Dadi tiranti prem.	A 194 Gr.8		
24	Stem nut	Dado serr. Stelo	A 194 Gr.8		

- (1) Silicon high temperature painture up to 600 °C 25 µ  
 (2) For temperature < - 20 °C s.s. A193 B8 + A194 Gr.8

Verniciatura siliconica resistente alle alte temperature 600 °C 25 µ  
 Per temperature < - 20 °C Acc. Inox A193 B8 + A194 Gr.8

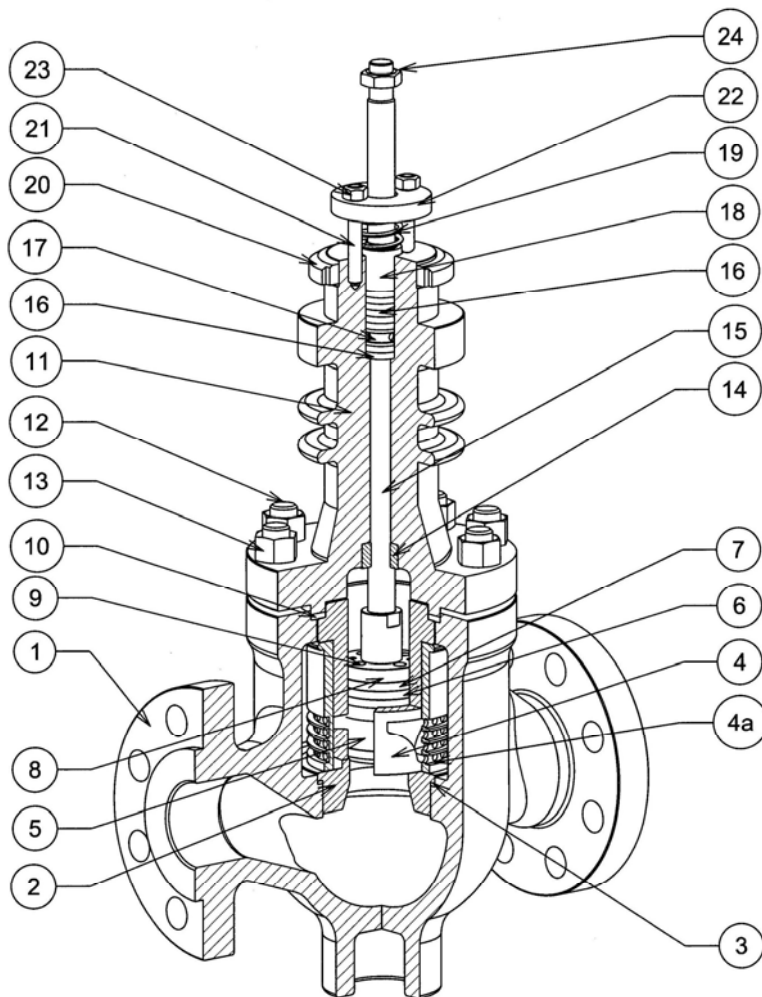

DN 50 - 100

**For soft seal class VI° see TRIM 1E**  
 Per la tenuta soffice classe VI°  
 vedi TRIM 1E

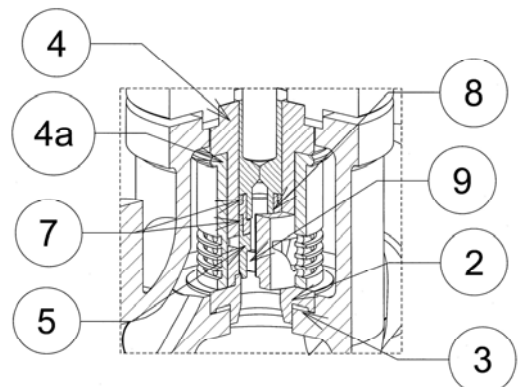

DN 25 - 40

TRIM 3EL			CARBON STEEL		STAINLESS STEEL
			Acciaio Carbonio		Acciaio Inox
TEMPERATURE RANGE			- 20 / +425 °C	- 45 / +343 °C	- 196 / +425 °C
Range Temperature					
Item	Description	Descrizione			
1	Body	Corpo	A 216 WCB (1)	A 352 LCB (1)	A351 CF8M
2	Seat	Sede	AISI 316 + stellite		
3	Seat Gasket	Guarnizione Sede	Thermiculite 815		
4	Main Equipercantage Cage	Gabbia principale	AISI 316		
4a	Second Cage	Seconda Gabbia	AISI 316		
4b	Third Cage	Terza Gabbia	AISI 316		
5	Piston	Pistone	AISI 316 + stellite		
6	Medium piston plate	Fondello intermedio	AISI 316		
7	Seal Rings	Anelli di Tenuta	Graphite + Antimon / Grafite + Antimonio		
8	Superior piston plate	Fondello Superiore	AISI 316		
9	Piston Screws	Viti Serr. Pistone	ISO 4762 Cl. A2		
10	Body Gasket	Guarnizione Corpo	Spirometal / Spirotallica – AISI 304 + Graphite		
11	Bonnet	Flangia superiore	A 216 WCB (1)	A 352 LCB (1)	A351 CF8M
12	Body Stud Bolts	Prigionieri corpo	A193 B7 galvanized	A193 B7 (2) galvanized	A193 B7 (2) galvanized
13	Body Nuts	Dadi	A194 2H galvanized	A194 2H (2) galvanized	A194 2H (2) galvanized
14	Guide bushing	Bussola guida	AISI 304		
15	Stem	Stelo	AISI 316		
16	Packing	Premistoppa	Pure Graphite – Grafite Pura		
			PTFE (PTFE V rings 100 %) TA-LUFT on request		
			PTFE/GR (PTFE V RINGS 85% + Graphite V rings 15 %)		
17	Snore-piece packing	Lanterna	AISI 316		
18	Packing Guide	Bussola prem.	AISI 316		
19	Packing Spring	Molla prem.	AISI 302		
20	Yoke Lock Nut	Ghiera blocc. Cast.	Carbon steel Cl. 6S galvanized – Acc. Carb. Zincato Cl. 6S		
21	Packing Stud Bolts	Tiranti prem.	A193 B8		
22	Packing flange	Flangia prem.	AISI 304		
23	Packing Lock Nuts	Dadi tiranti prem.	A 194 Gr.8		
24	Stem nut	Dado serr. Stelo	A 194 Gr.8		

- (1) Silicon high temperature painture up to 600 °C 25 µ  
 (2) For temperature < - 20 °C s.s. A193 B8 + A194 Gr.8

Verniciatura silconica resistente alle alte temperature 600 °C 25 µ  
 Per temperature < - 20 °C Acc. Inox A193 B8 + A194 Gr.8

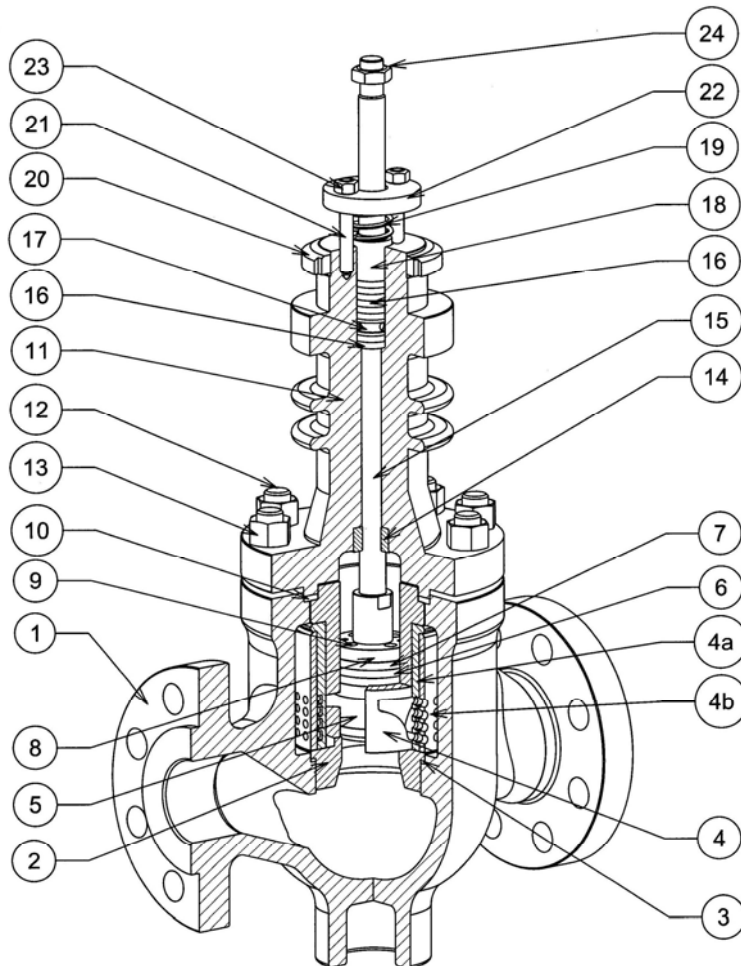

DN 50 - 100

**For soft seal class VI° see TRIM 1E**  
 Per la tenuta soffice classe VI°  
 vedi TRIM 1E

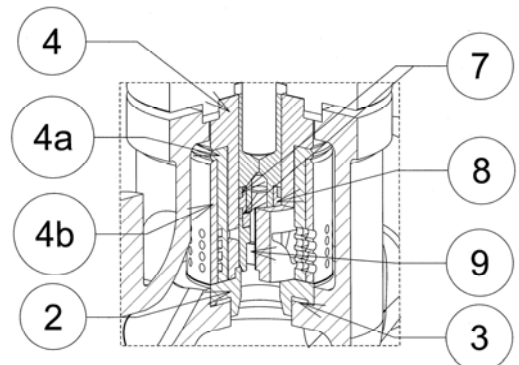

DN 25 - 40

TRIM CPL - CPE - CPT			CARBON STEEL		STAINLESS STEEL
			Acciaio Carbonio		Acciaio Inox
TEMPERATURE RANGE			-20 / +425 °C	-45 / +343 °C	-196 / +425 °C
Range Temperature					
Item	Description	Descrizione			
1	Body	Corpo	A 216 WCB (1)	A 352 LCB (1)	A351 CF8M
2	Seat	Sede	AISI 316 + stellite		
3	Seat Gasket	Guarnizione Sede	Thermiculite 815		
4	Main Cage	Gabbia principale	AISI 316		
5	Contoured Linear Plug (Fig.1) Equipercantage Plug (Fig.2) Quick-opening Plug (Fig.3)	Otturatore Profilato Lineare (Fig.1) Otturatore Profilato Equiperc. (Fig.2) Otturatore Apertura Rapida (Fig.3)	AISI 316 + stellite		
5a	Cage guide bushing	Bussola guida gabbia	AISI 304		
5b	Superior plug plate	Fondello superiore ten. soffice	AISI 316		
5c	Soft seal class VI°	Anello di tenuta classe VI°	PTFE or PTFE/GR		
5d	Plug screw	Vite serraggio otturatore	ISO 4762 Cl. A2		
10	Body Gasket	Guarnizione Corpo	Spirometal / Spirotallica - AISI 304 + Graphite		
11	Bonnet	Flangia superiore	A 216 WCB (1)	A 352 LCB (1)	A351 CF8M
12	Body Stud Bolts	Prigionieri corpo	A193 B7 galv.	A193 B7 (2) galv.	A193 B7 (2) galv.
13	Body Nuts	Dadi	A194 2H galv.	A194 2H (2) galv.	A194 2H (2) galv.
14	Guide bushing	Bussola guida	AISI 304		
15	Stem	Stelo	AISI 316		
16	Packing	Premistoppa	Pure Graphite - Grafite Pura		
			PTFE (PTFE V rings 100 %) <b>TA-LUFT on request</b>		
			PTFE/GR (PTFE V RINGS 85% + Graphite V rings 15 %)		
17	Snore-piece packing	Lanterna	AISI 316		
18	Packing Guide	Bussola prem.	AISI 316		
19	Packing Spring	Molla prem.	AISI 302		
20	Yoke Lock Nut	Ghiera blocc. Cast.	Carbon steel Cl. 6S galvanized - Acc. Carb. Zincato Cl. 6S		
21	Packing Stud Bolts	Tiranti prem.	A193 B8		
22	Packing flange	Flangia prem.	AISI 304		
23	Packing Lock Nuts	Dadi tiranti prem.	A 194 Gr.8		
24	Stem nut	Dado serr. Stelo	A 194 Gr.8		

- (1) Silicon high temperature painture up to 600 °C 25 µ  
 (2) For temperature < -20 °C s.s. A193 B8 + A194 Gr.8

Verniciatura siliconica resistente alle alte temperature 600 °C 25 µ  
 Per temperature < -20 °C Acc. Inox A193 B8 + A194 Gr.8

DN 25 - 50

Trim Types - Tipi di otturatore

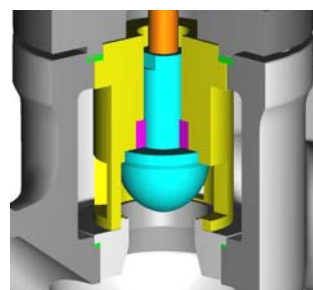
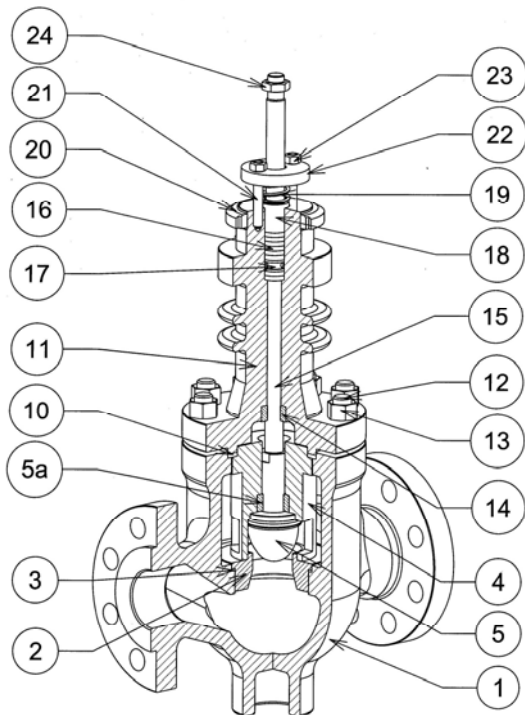

**CONTOURED LINEAR PLUG**  
 from DN 25 to DN 50  
 not balanced

OTTURATORE PROFILATO  
 LINEARE dal DN 25 al DN 50  
 non bilanciato

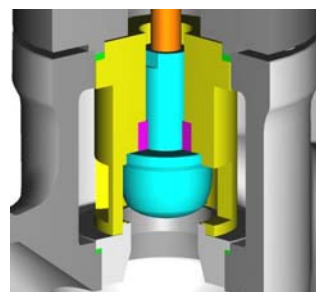

**CONTOURED EQUIPERCANTAGE PLUG**  
 from DN 25 to DN 50  
 not balanced

OTTURATORE PROFILATO  
 EQUIPERCENTUALE dal DN  
 25 al DN 50  
 non bilanciato

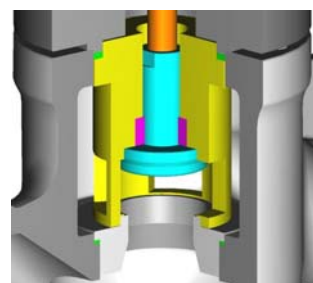

**QUICK-OPENING PLUG**  
 from DN 25 to DN 50  
 not balanced

OTTURATORE  
 APERTURA RAPIDA dal  
 DN 25 al DN 50  
 non bilanciato

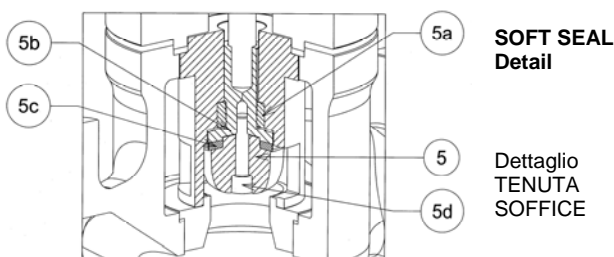

**SOFT SEAL Detail**

Dettaglio  
 TENUTA  
 SOFFICE



TRIM MFP - 1SG - 2SG			CARBON STEEL		STAINLESS STEEL
			Acciaio Carbonio		Acciaio Inox
TEMPERATURE RANGE			- 20 / +425 °C	- 45 / +343 °C	- 196 / +425 °C
Range Temperature					
Item	Description	Descrizione			
1	Body	Corpo	A 216 WCB (1)	A 352 LCB (1)	A351 CF8M
2	Seat	Sede	AISI 316 + stellite		
3	Seat Gasket	Guarnizione Sede	Thermiculite 815		
4	Main Cage	Gabbia principale	AISI 316		
5	Linear Plug MFP (Fig.1) Equiperc. Plug 1SG (Fig.2) Equiperc. Plug 2SG (Fig.3)	Otturatore Lineare MFP (Fig.1) Otturatore Equiperc. 1SG (Fig.2) Otturatore Equiperc. 2SG (Fig.3)	AISI 316 + stellite		
5a	Cage guide bushing	Bussola guida gabbia	AISI 304		
5c	Soft seal class VI°	Anello di tenuta classe VI°	PTFE or PTFE/GR		
10	Body Gasket	Guarnizione Corpo	Spirometal / Spirotallica - AISI 304 + Graphite		
11	Bonnet	Flangia superiore	A 216 WCB (1)	A 352 LCB (1)	A351 CF8M
12	Body Stud Bolts	Prigionieri corpo	A193 B7 galv.	A193 B7 (2) galv.	A193 B7 (2) galv.
13	Body Nuts	Dadi	A194 2H galv.	A194 2H (2) galv.	A194 2H (2) galv.
14	Guide bushing	Bussola guida	AISI 304		
15	Stem	Stelo	AISI 316		
16	Packing	Premistoppa	Pure Graphite - Grafite Pura		
			PTFE (PTFE V rings 100 %) <b>TA-LUFT on request</b>		
			PTFE/GR (PTFE V RINGS 85% + Graphite V rings 15 %)		
17	Snore-piece packing	Lanterna	AISI 316		
18	Packing Guide	Bussola prem.	AISI 316		
19	Packing Spring	Molla prem.	AISI 302		
20	Yoke Lock Nut	Ghiera blocc. Cast.	Carbon steel Cl. 6S galvanized - Acc. Carb. Zincato Cl. 6S		
21	Packing Stud Bolts	Tiranti prem.	A193 B8		
22	Packing flange	Flangia prem.	AISI 304		
23	Packing Lock Nuts	Dadi tiranti prem.	A 194 Gr.8		
24	Stem nut	Dado serr. Stelo	A 194 Gr.8		

- (1) Silicon high temperature painture up to 600 °C 25 µ  
 (2) For temperature < - 20 °C s.s. A193 B8 + A194 Gr.8

Verniciatura silconica resistente alle alte temperature 600 °C 25 µ  
 Per temperature < - 20 °C Acc. Inox A193 B8 + A194 Gr.8

DN 25

Trim Types - Tipi di otturatore

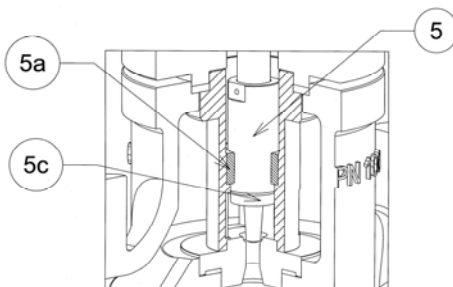
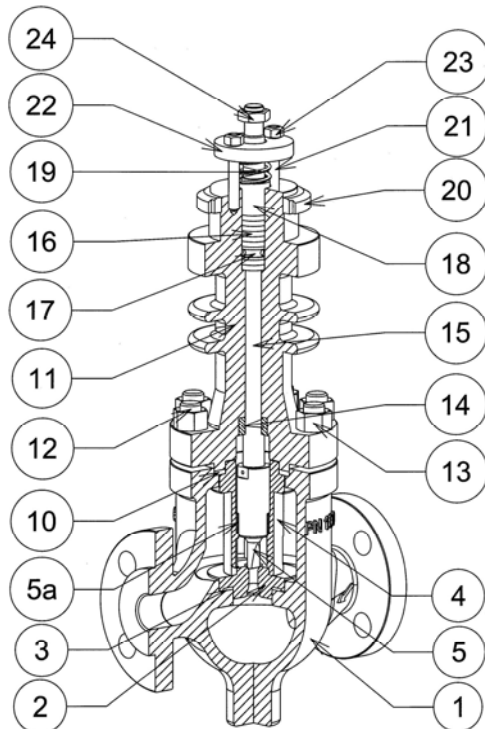

SOFT SEAL  
Detail

Dettaglio  
TENUTA  
SOFFICE

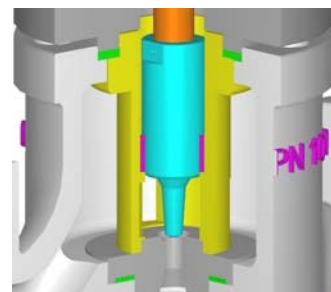

**CONTOURED MICROFLOW  
LINEAR PLUG MFP**  
(Ø 1/8"-3/16"-1/4"-3/8")  
not balanced

OTTURATORE PROFILATO  
LINEARE MICROFLUSSO  
(Ø 1/8"-3/16"-1/4"-3/8")  
non bilanciato

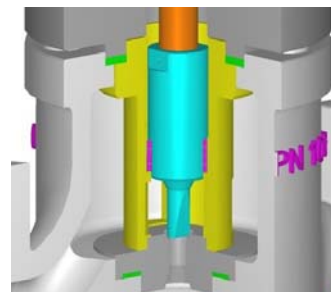

**CONTOURED MICROFLOW  
EQUIPERCAGE PLUG  
1SG**  
(Ø 1/4"-3/8") not balanced

OTTURATORE PROFILATO  
EQUIPERCENTUALE  
MICROFLUSSO 1SG  
(Ø 1/4"-3/8") non bilanciato

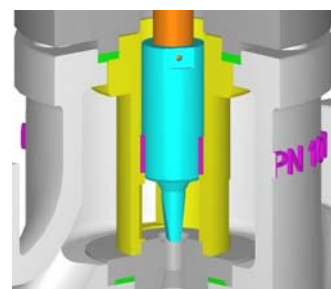

**CONTOURED MICROFLOW  
EQUIPERCAGE PLUG  
2SG**  
(Ø 1/4"-3/8") not balanced

OTTURATORE PROFILATO  
EQUIPERCENTUALE  
MICROFLUSSO 2SG  
(Ø 1/4"-3/8") non bilanciato

<i>Pneumatic Diaphragm Actuator RA reverse acting</i>	<i>Attuatore Pneumatico a Diaframma RA azione rovescia</i>
---	--

➔	<b>Pneumatic connections</b>	Connessioni pneumatiche	Ø 1/8" Rp ISO 7
	<b>Ambient temperature</b>	Temperatura ambiente	- 20 ... + 70 °C
	<b>Max supply air</b>	Massima press. di alimentazione	35 psi
	<b>Finishing</b>	Finitura	Epoxy coated 65 µ RAL 5020 – Polvere epoxy

Item	Description	Descrizione	
1	Yoke	Castello	GGG 50
2	Description plate	Targhetta descrittiva	S.S. AISI 304 – Acciaio Inox AISI 304
3	Travel indicator	Targhetta indice di corsa	Alluminium - Alluminio
4	Union block	Blocchetto di unione	AISI 304
5	Lock nut upper stem	Dado blocc. Asta superiore	A 194 Gr.8
6	Upper stem	Asta superiore	AISI 304
7	Lower "o" ring	"O" ring inferiore	NBR std
8	Upper Air tight	Corteco superiore	NBR std
9	Gasket	Guarnizione	Cork rubber – Sughero std
10	Internal screws	Viti interne	DIN 933 galvanized steel
11	Lower case	Cassa Attuatore Inferiore	P11 steel
12	Diaphragm spacer	Distanziale membrana	Galvanized steel
13	Diaphragm	Membrana	EPDM std
13.1	Spacer 6-30 psi (1)	Distanziale 6-30 psi	Carbon steel
14	Diaphragm Plate	Piatto Membrana	P01 steel
15	Diaphragm bush	Boccola membrana	AISI 303
16	Diaphragm lock screw	Vite serraggio membrana	ISO 7380 Galvanized steel
17	Springs	Molle	C98 UNI 3823
18	Upper case	Cassa attuatore superiore	P11 steel
19	Casing lock screws	Viti di serraggio	DIN 933 galvanized steel
20	Casing locknuts	Dadi di serraggio	DIN 933 galvanized steel
21	Eyebolts	Golfari	DIN 582 – galvanized C15

(1) Component mounted only on RA version T400/T500 6-30 psi      Componente montato solo nella versione RA T400/T500 6-30 psi

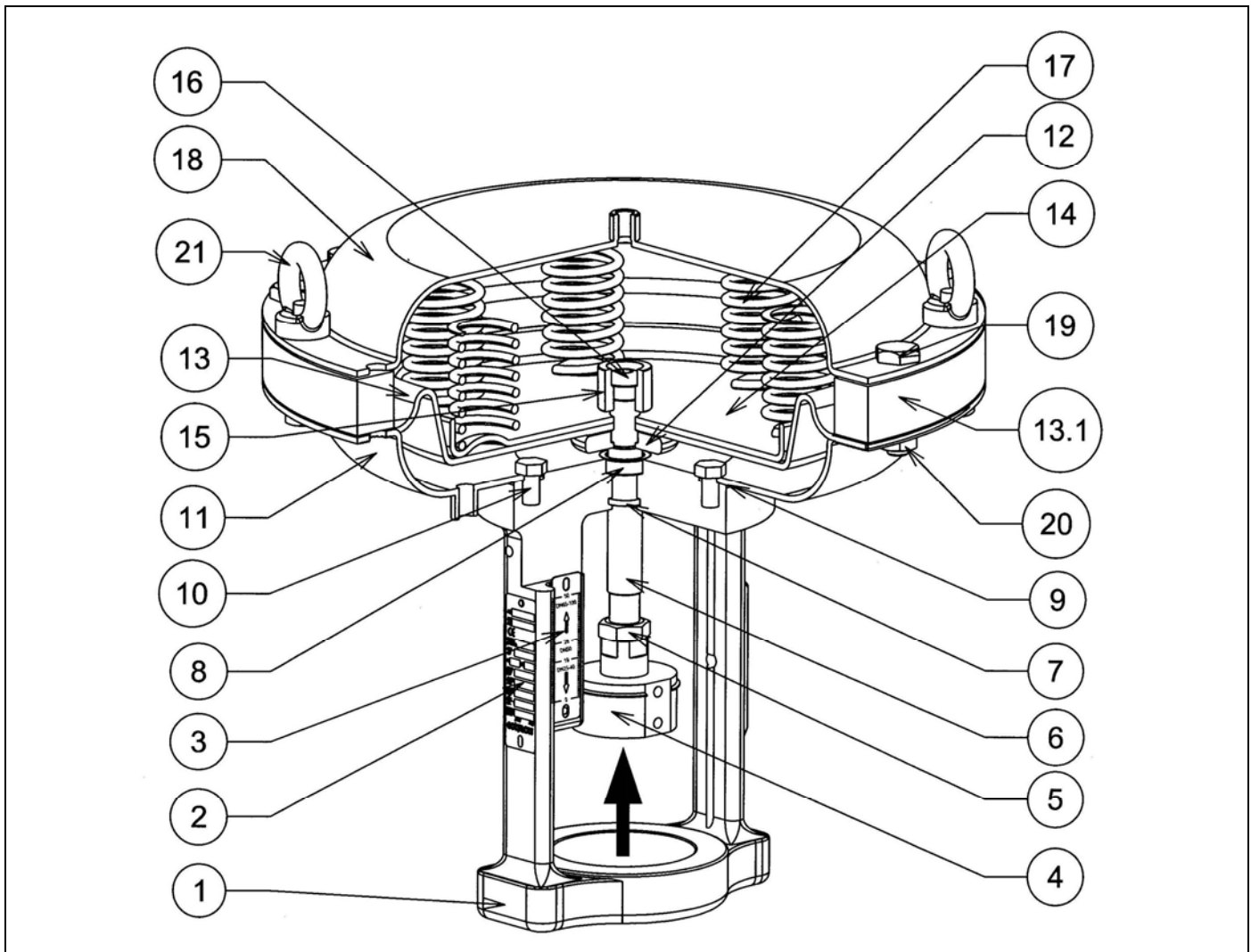

<i>Pneumatic Diaphragm Actuator DA direct acting</i>	<i>Attuatore Pneumatico a Diaframma DA azione diretta</i>
--	---

	<b>Pneumatic connections</b>	Conessioni pneumatiche	Ø 1/8" Rp ISO 7
	<b>Ambient temperature</b>	Temperatura ambiente	- 20 ... + 70 °C
	<b>Max supply air</b>	Massima press. di alimentazione	35 psi
	<b>Finishing</b>	Finitura	Epoxy coated 65 µ RAL 5020 – Polvere epoxy

Item	Description	Descrizione	
1	Yoke	Castello	GGG 50
2	Description plate	Targhetta descrittiva	S.S. AISI 304 – Acciaio Inox AISI 304
3	Travel indicator	Targhetta indice di corsa	Alluminium - Alluminio
4	Union block	Blocchetto di unione	AISI 304
5	Lock nut upper stem	Dado blocc. Asta superiore	A 194 Gr.8
6	Upper stem	Asta superiore	AISI 304
7	Lower "o" ring	"O" ring inferiore	NBR std
8	Upper Air tight	Corteco superiore	NBR std
9	Gasket	Guarnizione	Cork rubber – Sughero std
10	Internal screws	Viti interne	DIN 933 galvanized steel
11	Lower case	Cassa Attuatore Inferiore	P11 steel
12	Diaphragm spacer	Distanziale membrana	Galvanized steel
13	Diaphragm	Membrana	EPDM std
14	Diaphragm Plate	Piatto Membrana	P01 steel
15	Diaphragm bush	Boccola membrana	AISI 303
16	Diaphragm lock screw	Vite serraggio membrana	ISO 7380 Galvanized steel
17	Springs	Molle	C98 UNI 3823
18	Upper case	Cassa attuatore superiore	P11 steel
19	Casing lock screws	Viti di serraggio	DIN 933 galvanized steel
20	Casing locknuts	Dadi di serraggio	DIN 933 Galvanized steel
21	Eyebolts	Golfari	DIN 582 – galvanized C15

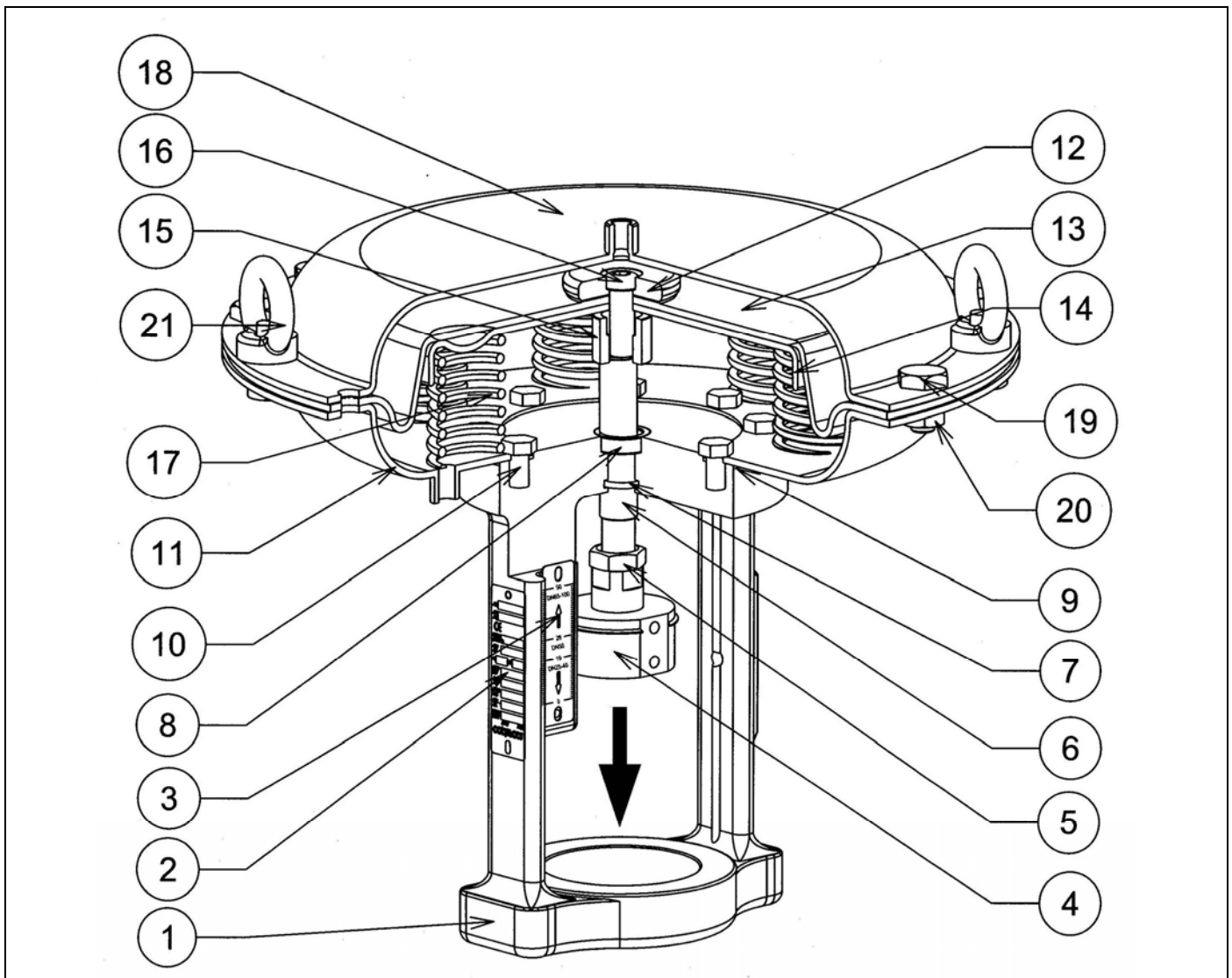

<i>Electric Actuator</i>	<i>Attuatore Elettrico</i>
--------------------------	----------------------------

	<b>Electric connections</b>	Connessioni elettriche	<b>Cable gland PG 13 (2off) – n° 2 Connessioni elettriche PG13</b>				
	<b>Degree of protection</b>	Grado di protezione	<b>IP 65 DIN 40050</b>				
	<b>Ambient temperature</b>	Temperatura ambiente	<b>- 20 ... + 60 °C</b>				
	<b>Power Supply</b>	Tensione di alimentazione	<b>24 V AC</b>	<b>24 V DC</b>	<b>110 V AC</b>	<b>230 V AC</b>	<b>400 V 3</b>

Item	Description	Descrizione	
1	<b>Cover</b>	Coperchio	<b>UV resistant, self extinguishing polycarbonate</b> Policarbonato autoestinguente – resistente UV
2	<b>Synchronous motor</b>	Motore sincrono	-
3	<b>Base case with internal gears</b>	Cassa con ingranaggi	<b>Alluminium die casting</b> Pressofusione in alluminio
4	<b>Guide bushing with disc spring coupling</b>	Guida con molle a disco	<b>Kevlar</b>
5	<b>Pillar yoke</b>	Colonne castello	<b>Non corrosive steel 1.4104 – Acciaio 1.4104</b>
5.1	<b>Travel indicator</b>	Targhetta indicatrice di corsa	<b>Alluminium - Alluminio</b>
5.2	<b>Description plate</b>	Targhetta descrittiva	<b>S.S. AISI 304 – Acciaio inox AISI 304</b>
6	<b>Manual handwheel</b>	Volantino manuale	<b>Duroplastic – Plastica indurita</b>
7	<b>Plate for limit stroke</b>	Piastra per limitatori di corsa	<b>Nickel plated steel – Acciaio nichelato chimicamente</b>

OPTIONALS		ACCESSORI	
8	<b>Plate for additional stroke switches</b>	Piastra per fine corsa aggiuntivi	<b>Nickel plated steel - Acciaio nichelato chimicamente</b>
9	<b>Single or double potentiometer</b>	Singolo o Doppio potenziometro	-
10	<b>Space heater</b>	Resistenza elettrica	-
11	<b>Electronic position transmitter</b>	Trasmettitore di posizione	-
12	<b>Electronic positioner</b>	Posizionatore elettronico	-

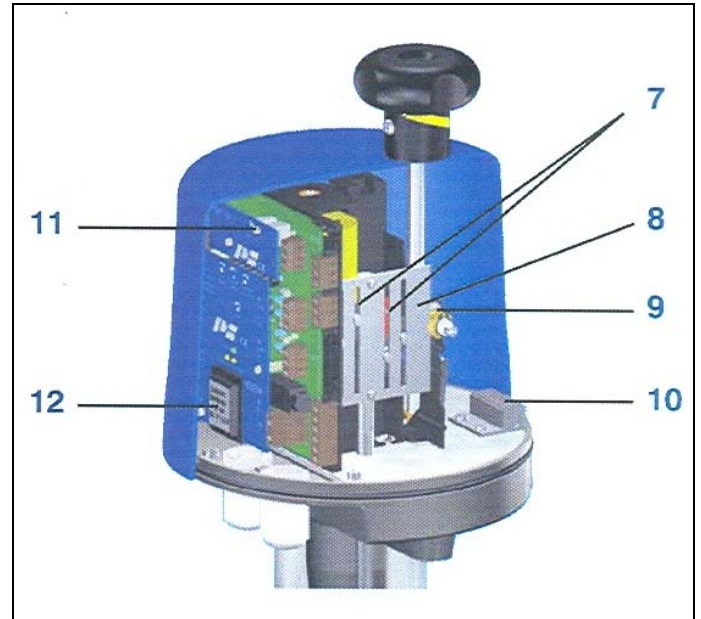
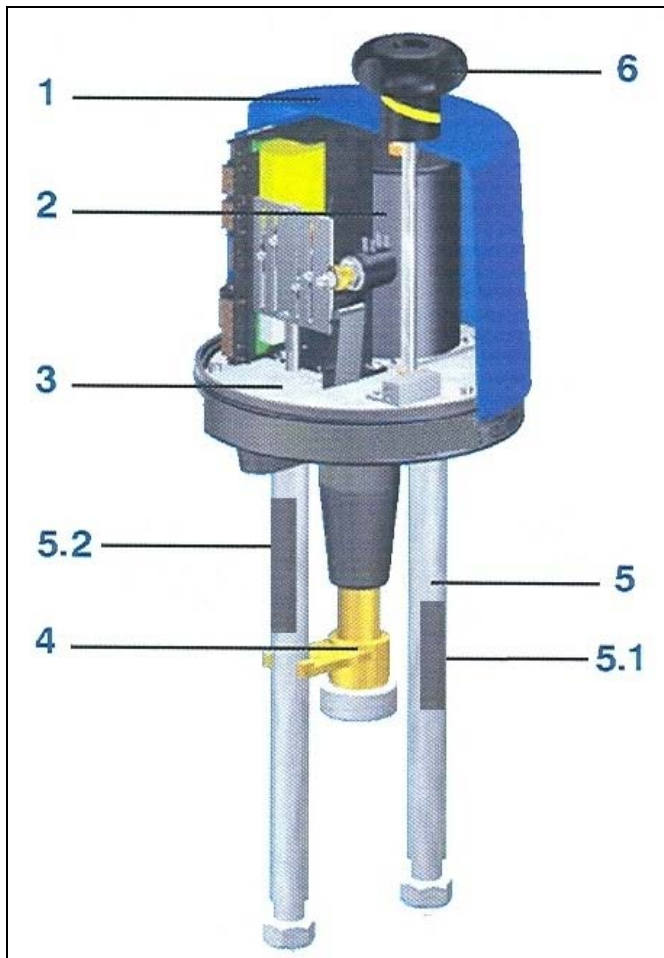

# HP 60 Series

Dimensions mm – Dimensioni mm

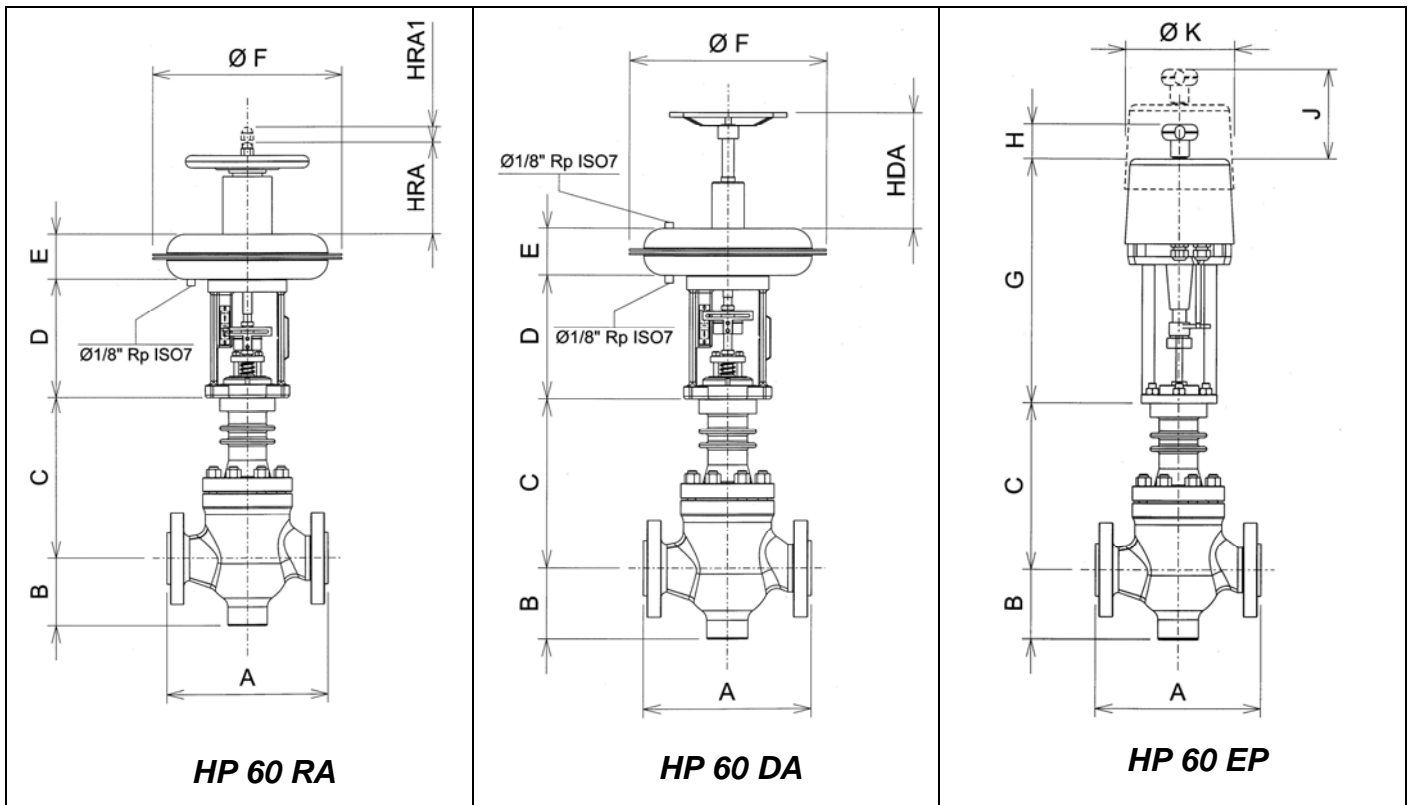

DN	Ø	A					B	C (2)	C – Bellows PN100	
		ANSI 150 – 300		ANSI 600		PN 63				PN 100
		RF BW-SW (1)	RJ ANSI 300	RF BW-SW (1)	RJ	Form B - C - D - E - F				
25	1"	197	210	210	210	210	99	276	355	
40	1.1/2"	235	248	251	251	251	101	291	370	
50	2"	267	283	286	289	286	111	291	370	
65	2.1/2"	292	308	311	314	311	136	315	503	
80	3"	317	333	337	340	337	139	318	506	
100	4"	368	384	394	397	394	169	348	518	

(1) BW-SW according ASME/ANSI B16.34 – BW-SW in accordo alla norma ASME/ANSI B16.34

(2) On request dimension for bonnet low temperature < -45°C

A richiesta dimensione per bonnet allungato per basse temperature < -45°C

ACTUATORS						ATTUATORI							
Type of Pneumatic Actuators	D	E			Ø F	HRA	HRA1	HDA	Type of Electric Actuators	G	H	Ø K	J
		HP60DA	HP60RA										
			psi	6-18									
T250	208	70	70	70	292	200	220	PSL201	450	50	176	100	
T310		95	95	95				336					PSL202
T400		119	119	144				408					PSL204
T500		119	119	144				520					PSL210
								PSL214	496	52	180	120	
								PSL320	784	47(3)	226	230	
							PSL325						

(3) ball headed button with side manual handwheel  
pomello – con volantino laterale

# HP 60 Series

Weights Kg - Pesi Kg

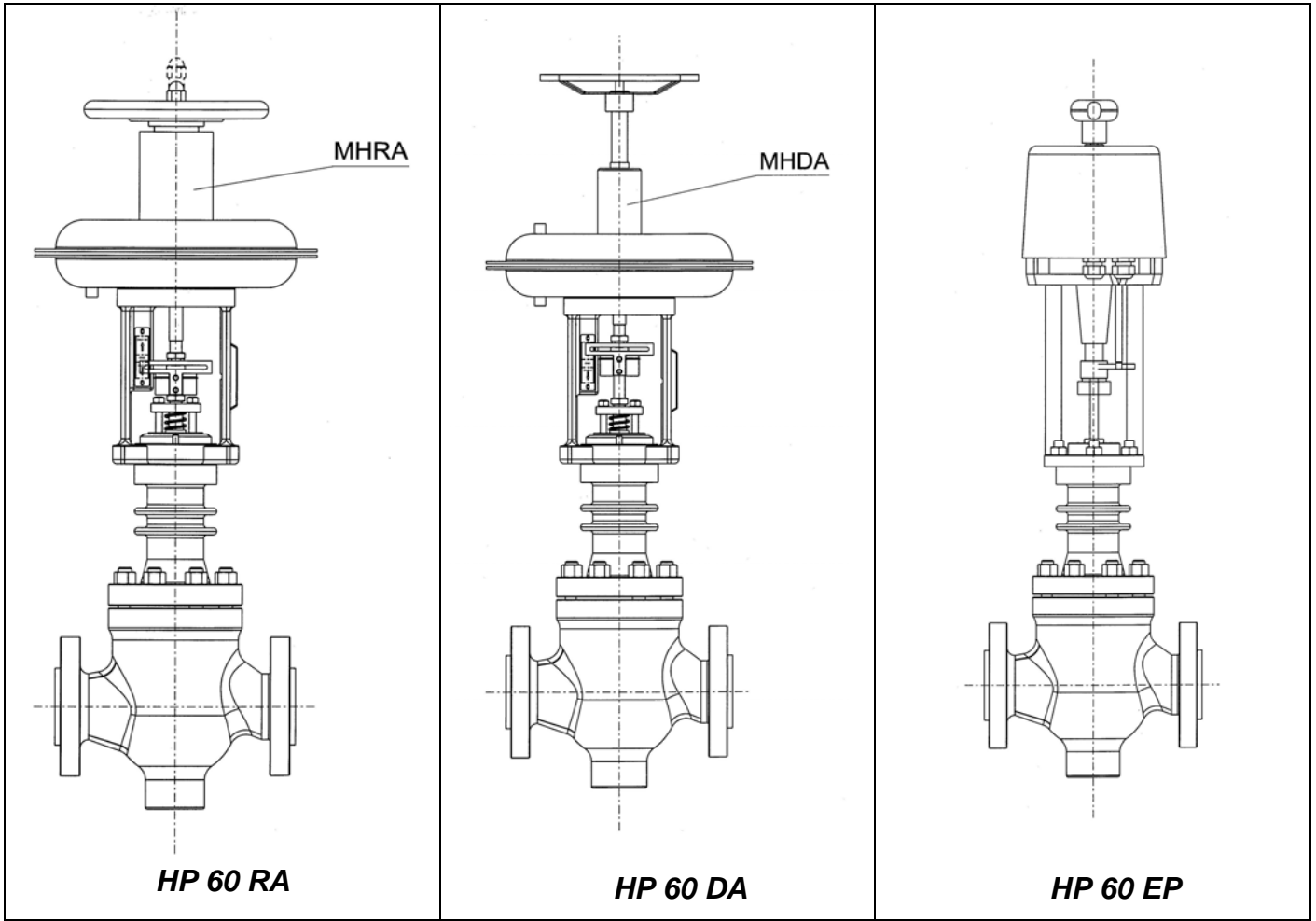

		BODY GROUP - weight Kg		GRUPPO CORPO - Peso Kg	
		ANSI 600		PN 63	PN 100
		RF - RJ	BW - SW	FORM B - C - D - E - F	
25	1"	23	20,5	24	24
40	1.1/2"	33	28,5	34	34
50	2"	40	35	40	41
65	2.1/2"	59	48	60	63
80	3"	66	53	64	66
100	4"	96	70	87	91

		ACTUATORS - weight Kg		ATTUATORI - peso Kg			
Type of Pneumatic Actuators	HP60 DA Direct Acting	HP60 RA Reverse Acting		MHDA	MHRA	Type of Electric Actuators	
	Signal psi	Signal psi					
	6-30	6-18	6-30				
T250	9,5	10	11	2,5	4,5	PSL201	6
T310	13	13,5	14			PSL202	6,5
T400	20	20,5	30			PSL204	8
T500	30	30,5	43			PSL210	9,5
						PSL214	11
						PSL320	21
						PSL325	21

NOTE : Accessories weight indicated on series data sheets  
Pesi accessori indicati sui data sheet della serie

# HP 60 Series

## SPECIAL OPTIONS

- Cleaning for Oxygen Service
- Special Materials
- ATEX Electric Actuator

## OPZIONI SPECIALI

- Pulizia per applicazione "Servizio Ossigeno"
- Materiali Speciali
- Attuatore elettrico ATEX

## SUGGESTED SPARE PARTS

### Components suggested as spare parts for commissioning and start-up

- seat body gasket
- main body gasket
- packing
- soft insert on plug

only for Pneumatic Actuator  
kit gaskets composed by :  
diaphragm  
Yoke gasket  
Air tight  
"O" ring

### After 2 Years exercise suggested spare parts

- Complete trim  
( seat + gaskets + packing included )
- Kit gasket for Pneumatic Actuator
- Electrical accessories (2% per type )

Special tools are not necessary for maintenance

## RICAMBI SUGGERITI

### Componenti suggeriti come ricambi per commissioning e avviamento

- guarnizione sede
- guarnizione corpo
- premistoppa
- tenuta soffice su otturatore

solo per Attuatore Pneumatico  
kit guarnizioni composto da :  
membrana  
guarnizione castello  
Corteco  
"O" ring

### Parti di ricambio consigliate dopo 2 anni di funzionamento

- Trim completo  
( incluso sede + guarnizioni + premistoppa )
- Kit guarnizioni per Attuatore Pneumatico
- Accessori Elettrici ( 2% per Tipo )

Non sono necessari per la manutenzione attrezzi speciali

---

# CONFLOW s.p.a.

FLOW CONTROL SOLUTIONS

QUALITY CERTIFIED COMPANY UNI EN ISO 9001 : 2008

Sales Department – Settore Commerciale

E-mail : [sales@conflow.it](mailto:sales@conflow.it) – [vendite@conflow.it](mailto:vendite@conflow.it)

Servicing Department – Servizio Assistenza

E-mail : [servicing@conflow.it](mailto:servicing@conflow.it)

Via Lecco, 69/71

20864 AGRATE BRIANZA (MB) - ITALY

Phone : +39 - (0)39 - 651705 / 650397

Fax : +39 - (0)39 – 65401

Web : [www.conflow.it](http://www.conflow.it)